

SERVICE MANUAL

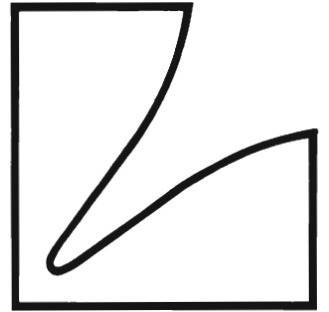

Stereo Cassette Deck

K-109



Contents

Specifications	3
Parts locations and Disassembly Instructions.	4 to 10
Adjustment Procedures.	11 to 27
Adjustment Locations	28 to 30
Block Diagram	31
Replacement of Mechanical Parts	32 to 35
Trouble Shooting Guide	36 to 39
Voltage Chart.	40 to 48
Parts Layout on P.C. Boards	49 to 57
Wiring Diagram	58 to 60
Schematic Diagram 1/3.	61 to 62
Schematic Diagram 2/3.	63 to 64
Schematic Diagram 3/3.	65 to 66
Electrical Parts List	67 to 78
Destination's Parts List.	79
Packing Method View.	80
Packing Assembly Parts List	80
Cabinet Assembly Parts List	81 to 82
Exploded View (Cabinet)	83 to 84
Exploded View (Cassette Deck)	85 to 86
Cassette Deck Assembly Parts List	87 to 88
Semi-Conductor Lead Identifications	89 to 95

Specifications

Recording System	4 Track, 2 Channel Stereo
Tape Speed	4.76 cm/sec. $\pm 1\%$
Wow and Flutter	0.03% (JIS WTD)
Signal to Noise Ratio ("A" Curve WTD, R/P, from 400 Hz 3% Dist. Point)	
Dolby NR Off.	Norm: 52 dB, CrO ₂ /Metal: 55 dB, Metal 50: 56 dB
Dolby B-Type NR On.	Norm: 60 dB, CrO ₂ /Metal: 62 dB, Metal 50: 63 dB
Dolby C-Type NR On.	Norm: 65 dB, CrO ₂ /Metal: 67 dB, Metal 50: 68 dB
Distortion (400 Hz, 0 dB, Metal Position)	3%
Frequency Response by Reference Tape (–25 dB Level, Dolby NR Off)	
Metal (TDK AC-712)	20 Hz to 21 KHz (± 3 dB)
Metal 50 (TDK AC-712)	20 Hz to 20 KHz (± 3 dB)
CrO ₂ (TDK AC-512)	20 Hz to 20 KHz (± 3 dB)
Normal (TDK AC-223)	20 Hz to 19 KHz (± 3 dB)
Bias Frequency	112.64 KHz
Erase Ratio	60 dB (125 Hz)
Crosstalk	60 dB (1 KHz, 0 dB)
Separation	35 dB (1 KHz, 0 dB)
Input Sensitivity	150mV
Output Level/Impedance	
Line	530mV ± 1.5 dB/47K ohm
Headphone.	300mV ± 2 dB/8 ohm
Fast Forward/Rewind Time (C-60)	90 sec.
Take Up Torque	35 to 60 gcm
Fast Forward/Rewind Torque	70 to 140 gcm
Power Consumption	40W
Power Source	120V, 220 ~ 240V, AC 50/60 Hz (AK Model only) 100V, AC 50/60 Hz (JA Model only)
Dimensions	438(W) x 124(H) x 346(D) mm
Weight.	9.3 Kg
Semiconductors	37 ICs, 87 Transistors, 21 FETs, 16 Zener Diodes, 76 Diodes

* Specifications and characteristics are subject to change without prior notice.

* Noise reduction system manufactured under licence from Dolby Laboratories Licensing Corporation.
"Dolby" and the double-D symbol are trademarks of Dolby Laboratories Licensing Corporation.

Parts Locations and Disassembly Instructions

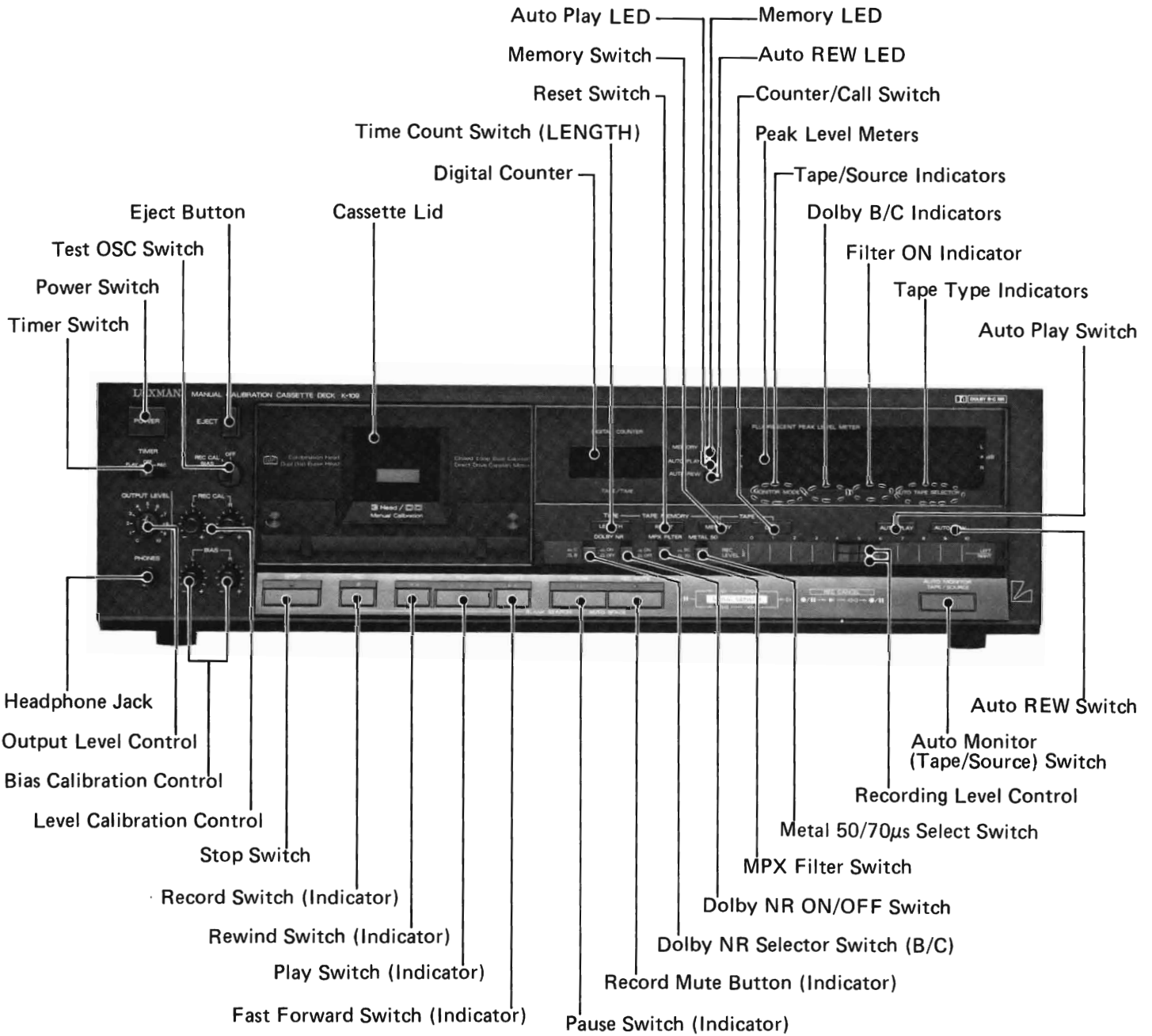

Figure 1

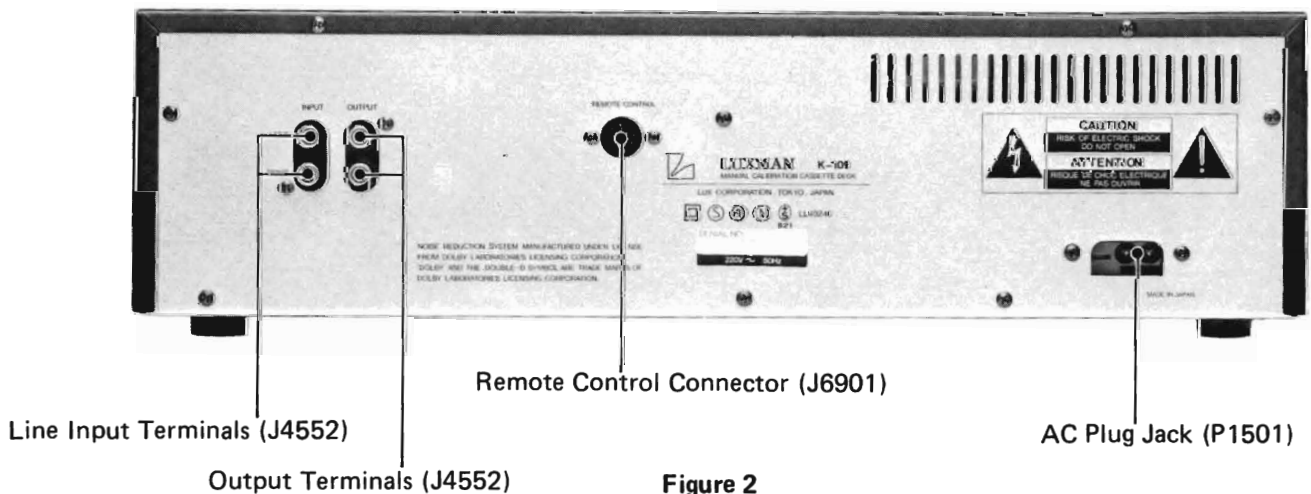

Figure 2

1. Removal of Top Cover

- (1) Remove eight screws marked "○" as shown in Figure 3.
- (2) Remove the top cover backward.

1. 上面カバーのはずし方

- (1) 8個のねじ○をはずします(3図参照)。
- (2) 上面カバーを後ろからはずします。

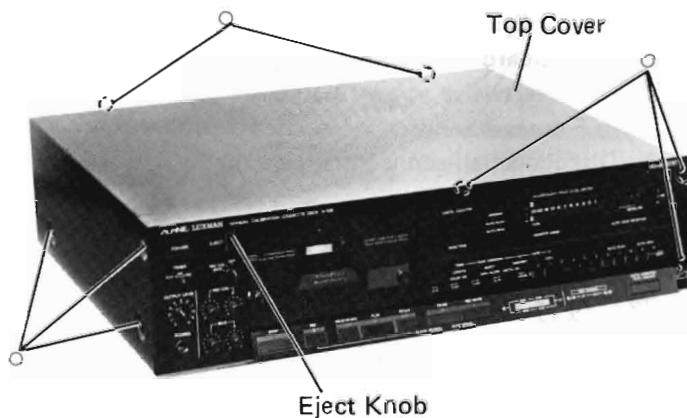

Figure 3

2. Removal of Control P.C. Board and Test Tone OSC P.C. Board

- (1) After removal of top cover, remove two clips as shown in Figure 4.
- (2) Remove six screws marked "□" as shown in Figure 4.
- (3) Disconnect all connectors from the P.C. Boards.

2. コントロールPC板, テストトーンOSC PC板のはずし方

- (1) 上面カバーをはずし, 2個のクリップをはずします(4図参照)。
- (2) 6個のねじ□印をはずします(4図参照)。
- (3) コントロールPC板, テストトーンOSC PC板から全てのコネクタをはずします。

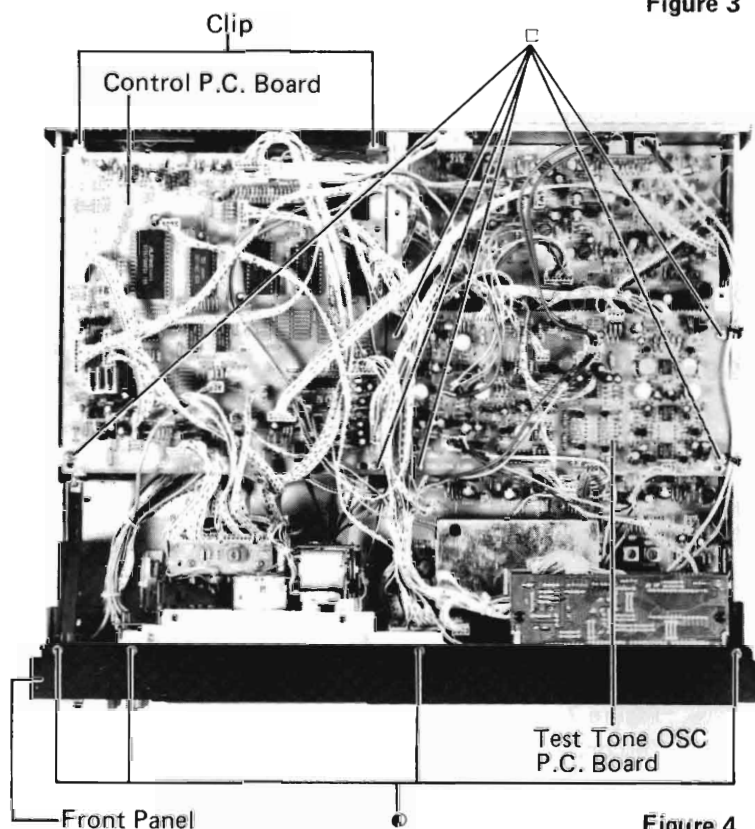

Figure 4

3. Removal of Front Panel

- (1) Push the eject knob to open the cassette door and remove the cassette door assembly upward as shown in Figure 3.
- (2) After removal of top cover, remove eight screws marked "●" as shown in Figures 4 and 5.
- (3) Remove the front panel.

3. 全面パネルのはずし方

- (1) イジェクトボタンを押してカセット蓋を開け, カセット蓋組立を上方向にはずします(3図参照)。
- (2) 上面カバーをはずした後, 8個のねじ●印をはずします(4図, 5図参照)。
- (3) 前面パネルをはずします。

4. Removal of Bottom Cover

- (1) After removal of front panel, remove six screws marked "☆" as shown in Figure 5.
- (2) Remove the bottom cover.

4. 底面カバーのはずし方

- (1) 前面パネルをはずし, 6個のねじ☆印をはずします(5図参照)。
- (2) 底面カバーをはずします。

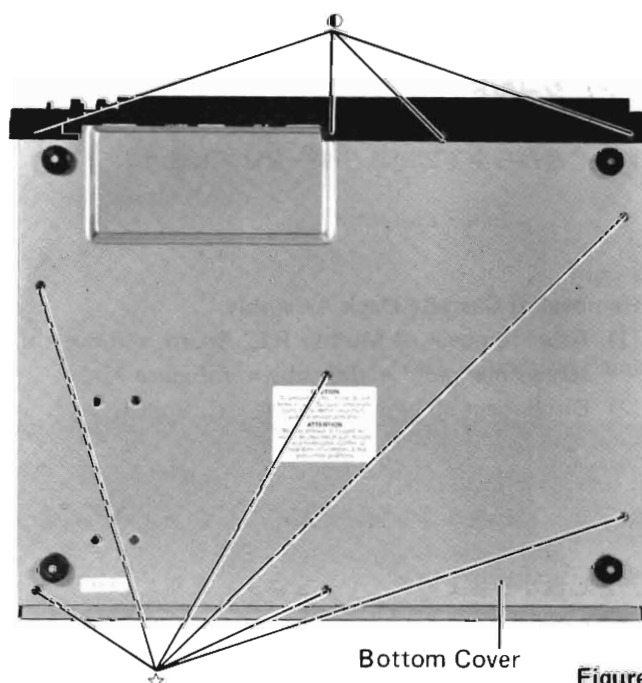

Figure 5

5. Removal of Bracket Panel and Rear Cover with Phone Plate P.C. Board and Remote Din P.C. Board

- (1) Remove twelve screws marked "■" as shown in Figures 7 and 8-1.
- (2) Disconnect all connectors from the P.C. Boards.

5. ブラケットパネル，後面カバーのはずし方 (フォーンプレートP.C.板，リモートDin P.C.板付)

- (1) 11個のねじ■印をはずします(7図，8-2図参照)
- (2) フォーンプレートP.C.板，リモートDin P.C.板から全てのコネクタをはずします。

6. Removal of Chassis Side R

- (1) After removal of rear cover and bottom cover, remove three screws marked "■" as shown in Figure 9.

6. シャーシサイドRのはずし方

- (1) 後面カバー，底面カバーをはずし，3個のねじ■印をはずします(9図参照)。

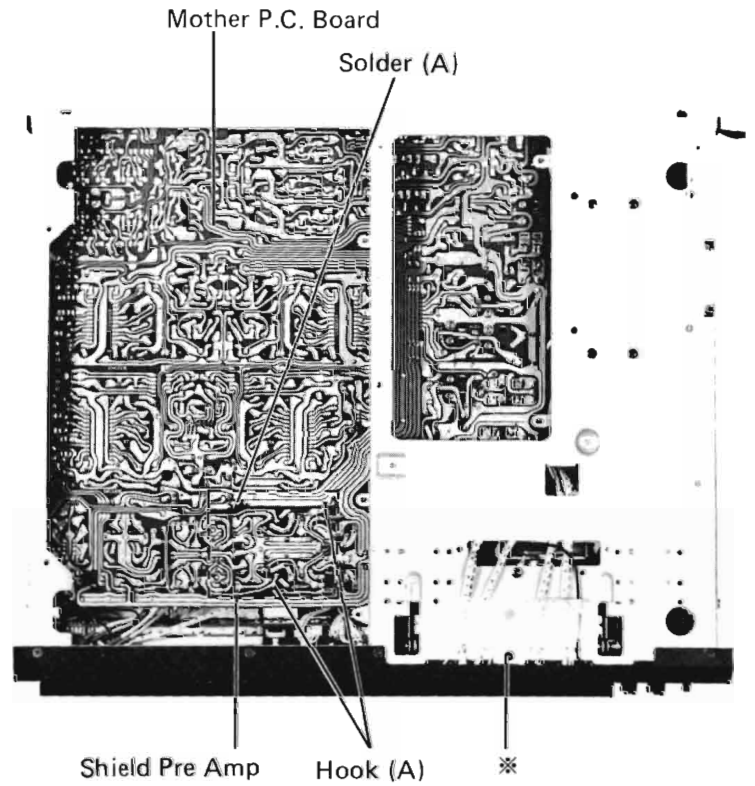

Figure 6

7. Removal of Mother P.C. Board

- (1) After removal of chassis side R and bracket panel, disconnect solder (A) and unfasten two hooks (A) as shown in Figure 6, then remove the shield pre-amp.
- (2) Remove four screws marked "△" as shown in Figure 7.
- (3) Disconnect all connectors from the P.C. Board.

7. マザーP.C.板のはずし方

- (1) シャーシサイドR，ブラケットパネルをはずします。ハンダ(A)をはずし，2個のフック(A)をはずすと，シールド・プリアンプははずれます(6図参照)。
- (2) 4個のねじ△印をはずします(7図参照)。
- (3) P.C.板から全てのコネクタをはずします。

8. Removal of Cassette Deck Assembly

- (1) After removal of Mother P.C. Board, remove six screws marked "★" as shown in Figure 7.
- (2) Disconnect all wires from the P.C. Board.

8. カセットデッキ組立のはずし方

- (1) マザーP.C.板をはずし，6個のねじ★印をはずします(7図参照)。
- (2) P.C.板から全てのワイヤーをはずします。

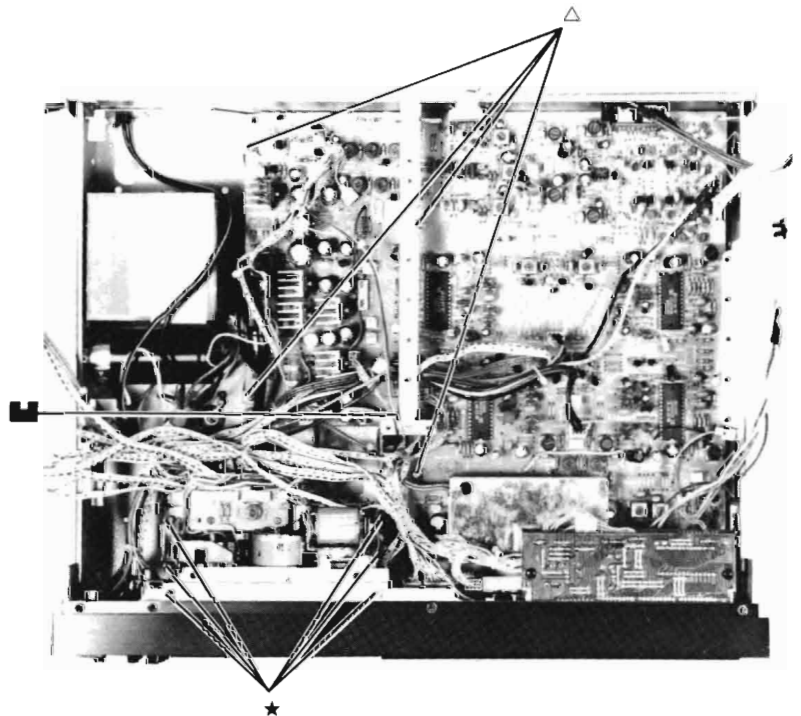

Figure 7

9. Removal of Keyboard Switch P.C. Board and Monitor Switch P.C. Board

- (1) After removal of chassis side R and cassette deck assembly, remove three screws marked "◎" as shown in Figures 9 and 10.
- (2) Disconnect all wires from the P.C. Boards.
- (3) Remove three screws marked "▲" and unfasten four hooks (A) as shown in Figure 11.

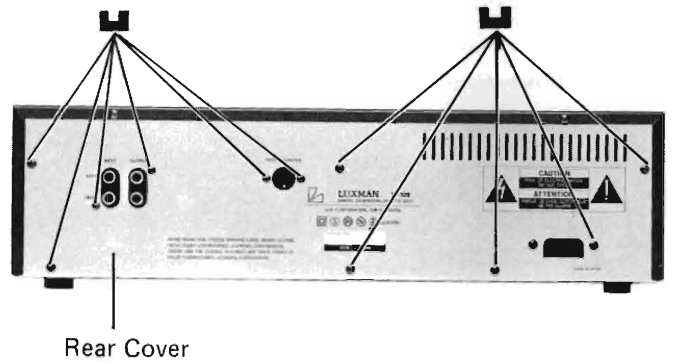

Figure 8-1

9. キーボードスイッチPC板, モニタースイッチPC板のはずし方

- (1) シャーシサイドRとカセットデッキ組立をはずした後3個のねじ◎印をはずします(9図, 10図参照)
- (2) PC板から全てのワイヤーをはずします。
- (3) 3個のねじ▲印をはずし, 4個のフック(A)をはずします(11図参照)。

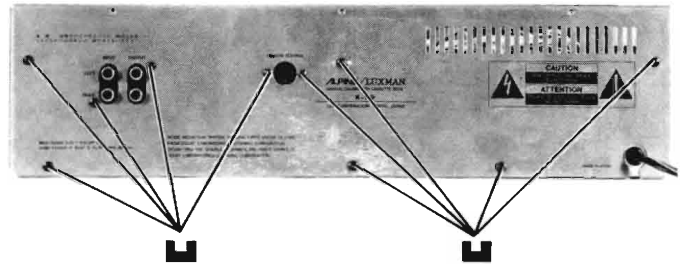

Figure 8-2

10. Removal of Front Chassis

- (1) After removal of function panel, remove the power switch knob as shown in Figure 12.
- (2) Remove three screws marked "※" as shown in Figures 6 and 12.
- (3) Disconnect all connectors from the P.C. Board.

10. 前面シャーシのはずし方

- (1) ファンクションパネルをはずし, 電源スイッチつまみをはずします(12図参照)。
- (2) 3個のねじ※印をはずします(6図, 12図参照)。
- (3) PC板から全てのコネクタをはずします。

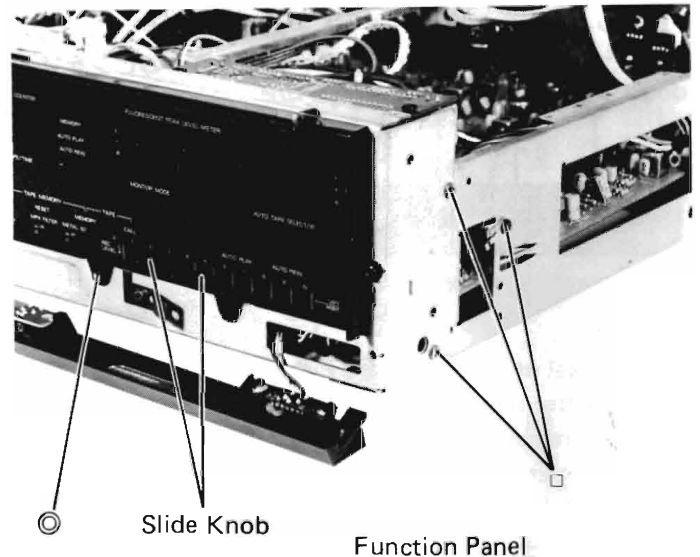

Figure 9

11. Removal of FL Meter P.C. Board

- (1) After removal of front chassis, unfasten two hooks (B) as shown in Figure 13.
- (2) Disconnect all connectors from the P.C. Board.

11. FLメーターPC板のはずし方

- (1) 前面シャーシをはずし, 2個のフック(B)をはずします(13図参照)。
- (2) PC板から全てのコネクタをはずします。

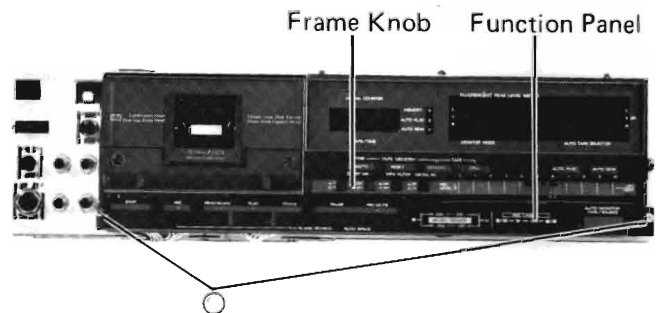

Figure 10

12. Removal of LED P.C. Board

- (1) After removal of front chassis, unfasten two hooks (C) as shown in Figure 13.
- (2) Disconnect the connector from the P.C. Board.

12. LED PC板のはずし方

- (1) 前面シャーシをはずし、2個のフック(C)をはずします(13図参照)。
- (2) PC板からコネクタをはずします。

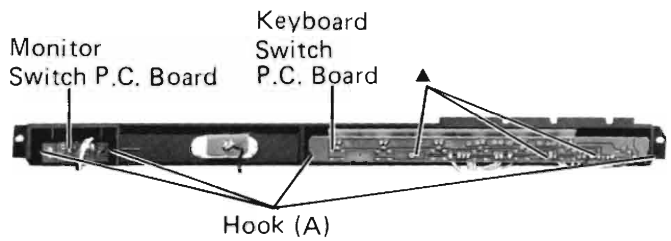

Figure 11

13. Removal of FL Counter P.C. Board

- (1) After removal of front chassis, unfasten two hooks (D) as shown in Figure 13. Pull out the FL Counter P.C. Board upward.
- (2) Disconnect all connectors from the P.C. Board. Do not snap pins of FL counter when disconnecting all connectors.

13. FLカウンターPC板のはずし方

- (1) 前面シャーシをはずし、2個のフック(D)をはずします(13図参照)。FLカウンターPC板を上へ引き出します。
- (2) PC板から全てのコネクタをはずします。コネクタをはずす時、FLカウンターのピンをはずさないようにしてください。

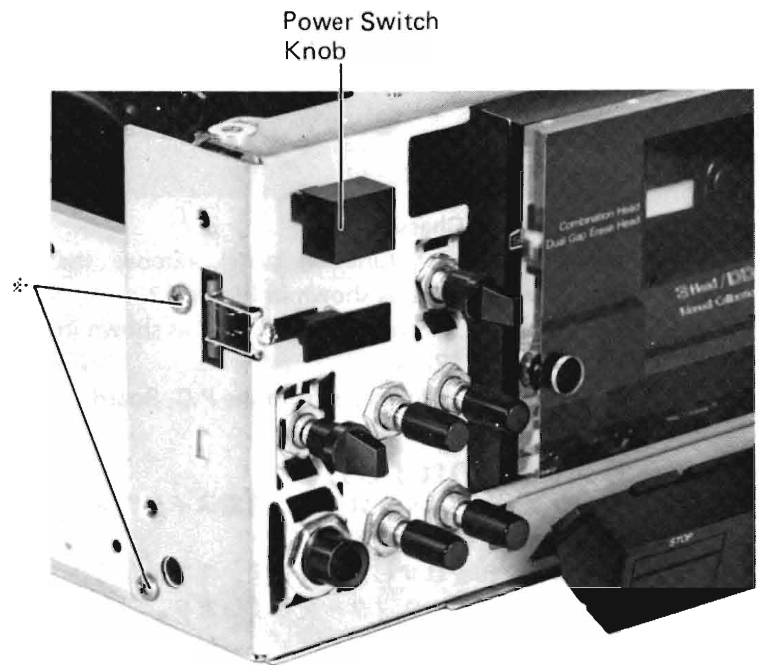

Figure 12

14. Removal of Sub Keyboard P.C. Board

- (1) After removal of FL Counter P.C. Board, remove three screws marked "◆" as shown in Figure 13, then remove the frame knob with the P.C. Board.

14. サブ・キーボードPC板のはずし方

- (1) FLカウンターPC板をはずします。3個のねじ◆印をはずし、PC板とフレームつまみをはずします。

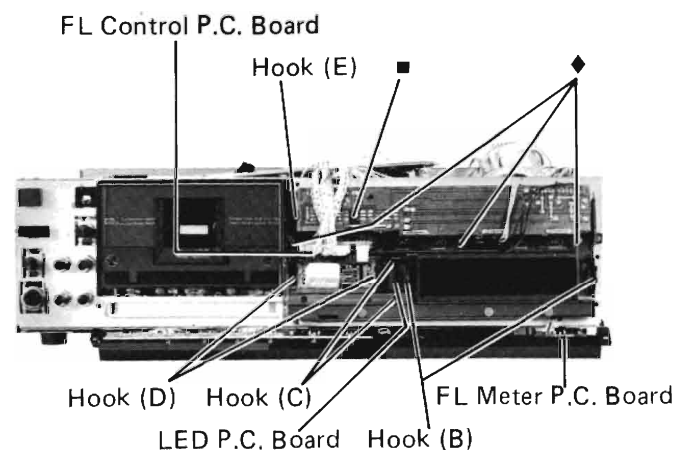

Figure 13

15. Removal of Volume/Switch P.C. Board

- (1) After removal of Sub Keyboard P.C. Board, remove two slide knobs as shown in Figure 9.
- (2) Tear off plate volume.
Use new plate volume when reassembling volume/switch P.C. Board.
- (3) Remove five screws marked "■" and unfasten hook (E) as shown in Figures 13 and 14.
- (4) Disconnect all connectors from the P.C. Board.

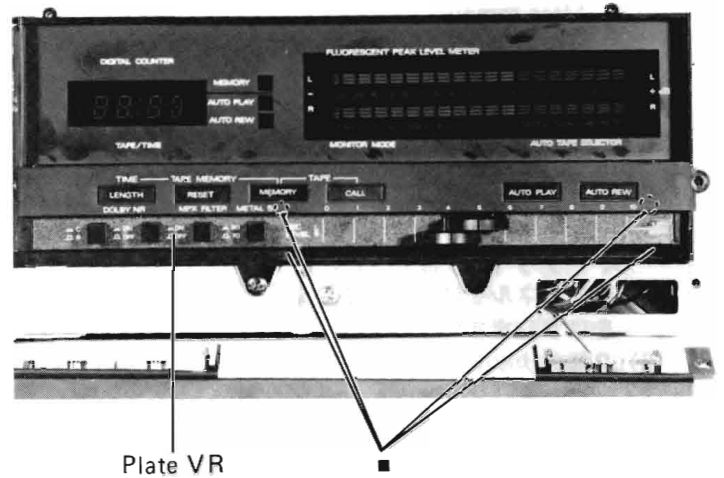

Figure 14

15. ボリューム/スイッチPC板のはずし方

- (1) サブ・キーボードPC板をはずし、2個のスライド式つまみをはずします(9図参照)。
- (2) プレートボリュームを割ります。
ボリューム/スイッチPC板を再び取り付けるときには、新しいプレートボリュームを使います。
- (3) 5個のねじ■印をはずし、フック(E)をはずします(13図、14図参照)。
- (4) PC板から全てのコネクタをはずします。

16. Removal of Timer Switch P.C. Board

- (1) After removal of Front Panel, remove knob (A) and remove two screws marked "凸" as shown in Figure 15.
- (2) Disconnect all connectors from the P.C. Board.

16. タイマースイッチPC板のはずし方

- (1) フロントパネルをはずします。
つまみ(A)をはずし、2個のねじ凸印をはずします(15図参照)。
- (2) PC板から全てのコネクタをはずします。

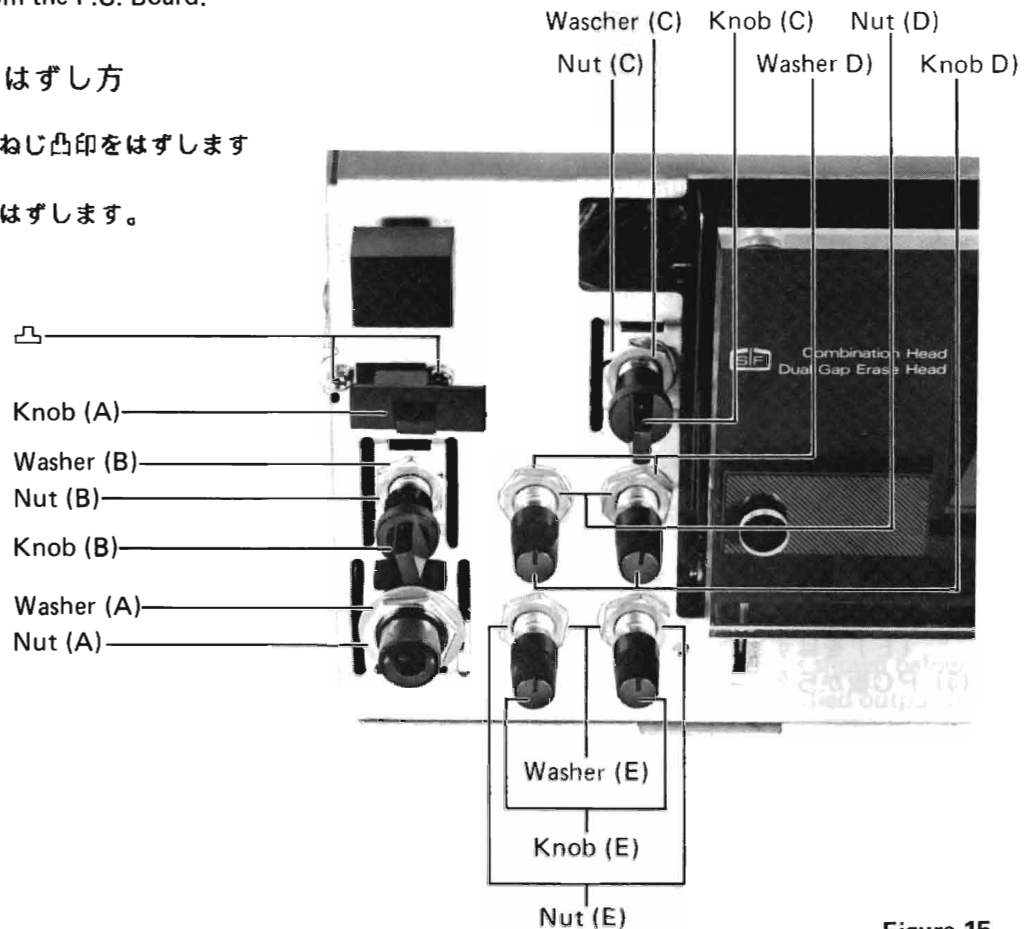

Figure 15

17. Removal of Output Volume P.C. Board and Test Tone OSC Switch P.C. Board

- (1) After removal of front panel, remove two rotary knobs (B), (C) as shown in Figure 15.
- (2) Remove two nuts (B), (C) and two washer (B), (C) as shown in Figure 15.
- (3) Disconnect all connectors from the P.C. Board.

17. 出力ボリュームPC板，テストトーンOSCスイッチPC板のはずし方

- (1) 前面パネルをはずし，2個の回転つまみ（B），（C）をはずします（15図参照）。
- (2) 2個のナット（B），（C）を2個のワッシャー（B）（C）をはずします（15図参照）。
- (3) PC板から全てのコネクタをはずします。

18. Removal of Head Phone P.C. Board

- (1) After removal of front panel, remove the nut (A) and washer (A) as shown in Figure 15.
- (2) Disconnect all connectors from the P.C. Board.

18. ヘッドフォンPC板のはずし方

- (1) 前面パネルをはずし，ナット（A）とワッシャー（A）をはずします（15図参照）。
- (2) 全てのコネクタをPC板からはずします。

19. Removal of Level Volume P.C. Board and Bias Volume P.C. Board

- (1) After removal of front panel, remove four knobs (D), (E) as shown in Figure 15.
- (2) Remove four nuts (D), (E) and four washers (D), (E) as shown in Figure 15.
- (3) Disconnect all connectors from the P.C. Boards.

**19. レベルボリュームPC板，バイアスポリ
リュームPC板のはずし方**

- (1) フロントパネルをはずし，4個のつまみ（D），（E）をはずします（15図参照）。
- (2) 4個のナット（D），（E）と4個のワッシャー（D）（E）をはずします（15図参照）。
- (3) PC板から全てのコネクタをはずします。

Adjustment Procedures

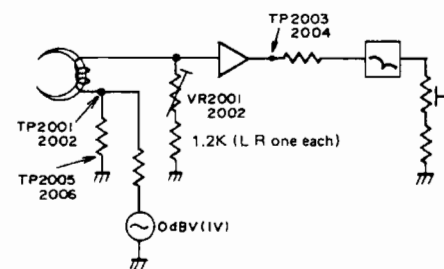
Step	Adjustment Items	Mode	Adjustment Parts	Test Points	Connection	Remarks												
1	Head Height and Tilt Angle		Screws A, B (Figure 16)			<ul style="list-style-type: none"> Measurement Gauge: M-300 1. Head Height (Figure 17) The guide check bar should smoothly pass through the tape guide. 2. Tilt Angle (Figure 18) The guide check bar should stay in parallel with the guide plate or the top of the guide check bar should tilt a little forward you. 												
2	Tape Guide of Supply Pinch Roller		Screw D (Figure 16)			<ul style="list-style-type: none"> Measurement Gauge: M-300 The guide check bar should smoothly pass through the tape guide of supply pinch roller. (Figure 17) 												
3	Head Azimuth	PLAY	Screw C (Figure 16)	TP3501(L) TP3502(R)	Figure 19	<ul style="list-style-type: none"> Test Tape: MTT-114 (10 KHz) The left and right outputs are in-phase and maximum and equal in amplitude. If the azimuth screw movement is too large, readjust the head height and Tilt angle in step 1. 												
4	Tape Speed	PLAY	VR1	LINE OUT	Figure 20	<ul style="list-style-type: none"> Test Tape: MTT-111 (3,000 Hz) Adjust VR1 to obtain output frequency reading of $3,000 \pm \frac{10}{0}$ Hz at Line Out. 												
5	Play back EQ and Peak Point	STOP T.Select: NORM	VR2001(L) VR2002(R)	TP2003(L) TP2004(R)	Figure 21	 <p>1. Set unit to playback mode with a blank tape loads.</p> <p>2. Apply 200 Hz test signal from AF OSC and adjust the OSC output until 1.0V output (= 0 dB) is obtained at test point TP2003 (TP2004). Change test signal frequency as shown below and adjust so that specified output is obtained at the test point(s). Refer to table below.</p> <table border="1" data-bbox="1053 1859 1484 1993"> <thead> <tr> <th></th> <th>Check</th> <th>Check</th> <th>Adjustment</th> </tr> </thead> <tbody> <tr> <td>Frequency Hz</td> <td>20</td> <td>6K</td> <td>20K</td> </tr> <tr> <td>Output dB</td> <td>11.5</td> <td>-15.5</td> <td>-12.0</td> </tr> </tbody> </table> <p>3. Check for -19.5 dB output at 6 kHz when Metal position is selected.</p>		Check	Check	Adjustment	Frequency Hz	20	6K	20K	Output dB	11.5	-15.5	-12.0
	Check	Check	Adjustment															
Frequency Hz	20	6K	20K															
Output dB	11.5	-15.5	-12.0															

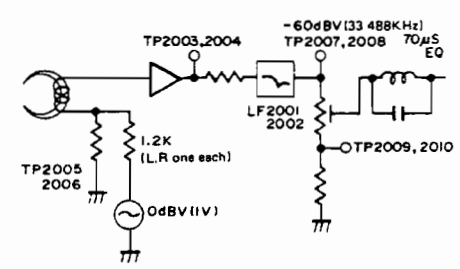
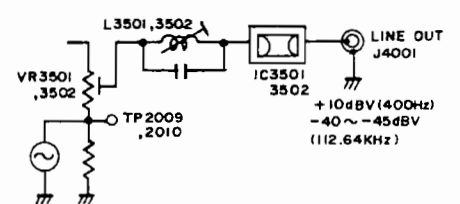

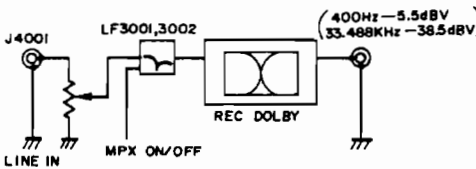
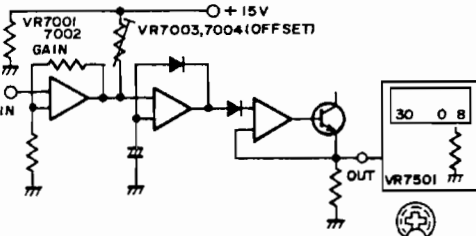
Step	Adjustment Items	Mode	Adjustment Parts	Test Points	Connection	Remarks
6	Playback Filter	STOP T. Select: NORM	LF2001(L) LF2002(R)	TP2007(L) TP2008(R)	Figure 21	 <p>1. Under condition of step 5, change AF OSC frequency to 33.488 KHz, and adjust minimum output is obtained at test point(s) and phases of L and R channels are the same.</p>
7	Playback Bias Trap	PLAY T. Select: NORM	L3501(L) L3502(R)	TP2009(L) TP2010(R) LINE OUT	Figure 22	 <p>1. Set Unit to playback mode with a blank tape loads. 2. AF OSC: 400 Hz Adjust VR3501, VR3502 to obtain +10 dB at LINE OUT. 3. Apply 112.64 KHz signal from AF OSC and adjust for minimum LINE OUTPUTs with the same phase.</p>
8	Dolby Level	PLAY T. Select: NORM NR: OFF	VR3501(L) VR3502(R)	TP3501(L) TP3502(R)	Figure 19	Test Tape: MTT-150 (400 Hz) Adjust to obtain -10 dBm output at each test point.
9	Input Sensitivity Reference level	STOP MONI- TOR: SOURCE	REC LEVEL VOLUME VR2301(L) VR2302(R)	TP3001(L) TP3002(R)	Figure 23	AF OSC: 400 Hz, 135mV LINE IN Input. Adjust to obtain -10 dBm output at each test point.

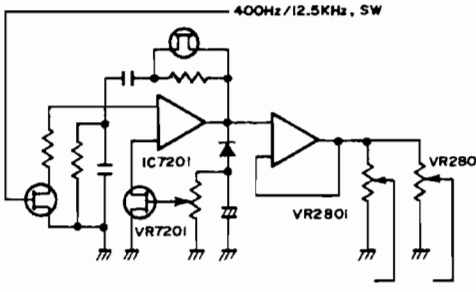
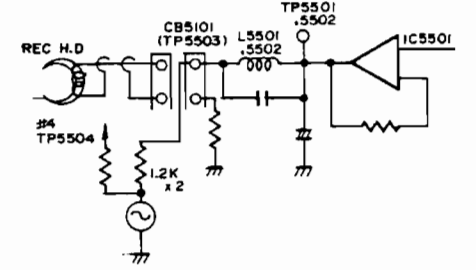
Step	Adjustment Items	Mode	Adjustment Parts	Test Points	Connection	Remarks
10	MPX Filter	STOP MONITOR SOURCE NR: OFF MPX SW: OFF	LF3001(L) LF3002(R)	LINE OUT	Figure 22	 <ol style="list-style-type: none"> 1. AF OSC: 400 Hz, 135mV LINE IN Input. 2. Make sure line output is 538mV = 0 dB (reference) 3. Change AF OSC output frequency to 33.488 KHz, and adjust for minimum line output(s) and the same phase for both L and R channels. 4. Next, set MPX on and AF OSC to 19 KHz. Make sure line output level is decreased by 30 dB or more. If not, go back to step 2 and change $f = 33.488$ KHz to another frequency and adjust so that specified attenuation of 30 dB is obtained, in this case phases for L and R channels should also be the same.
11	(1) Level Meter Adjustment	STOP MONITOR: SOURCE NR: OFF TEST TONE: OFF	VR7001(L) VR7002(R) VR7003(L) VR7004(R) VR7501	FL METER	Figure 23	 <ol style="list-style-type: none"> 1. AF OSC: 400 Hz, 135mV (Dolby level) Input. 2. Set VR7501 to mechanical center position. 3. Adjust VR7001, VR7002 until 0 ~ +1 dots of level meter light up. 4. AF OSC: Decrease oscillator output level by 27 dB. 5. Adjust VR7003, VR7004 until 30 ~ 20 dots of level meter light up. 6. AF OSC: Decrease oscillator output level by 28 dB. 7. Adjust VR7003, VR7004 until 30 ~ 20 dots of level meter turns off. 8. Repeat above steps until no further improvement is obtained.

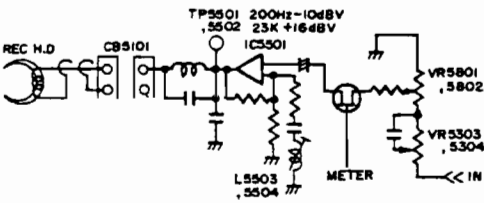
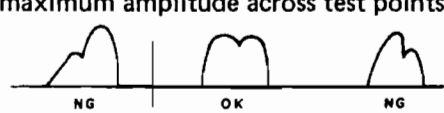
Step	Adjustment Items	Mode	Adjustment Parts	Test Points	Connection	Remarks
11	(2) TONE OSC Level	STOP MONITOR: SOURCE NR: OFF TEST TONE: REC CAL : BIAS	VR7201 VR2801(L) VR2802(R)	FL Meter LINE OUT	Figure 23	 <ol style="list-style-type: none"> 1. Set VR7201 to min. position. 2. Adjust VR2801, VR2802 until 0 ~ + 1 dots of level meter light up. 3. Check line output level with Test Tone switch set in REC CAL position. 4. Set Test Tone switch to BIAS position, and make sure the line output level is the same as that obtained under REC CAL position. Also make sure the level meter shows the same level as that obtained under REC CAL position.
12	REC Bias Trap	REC/PLAY T. Select: METAL	L5501(L) L5502(R)	TP5501 (L) TP5503 (CB5101, #1) TP5502 (R) TP5504 (CB5101, #4) TP5001	Figure 24	 <ul style="list-style-type: none"> ● TEST TAPE: BLANK TAPE <ol style="list-style-type: none"> 1. Disconnect REC HEAD from connector (CB5101). 2. Connect TP5001 to chassis: BIAS OFF. 3. AF OSC: 112.64 KHz, 0 dBV input. Adjust for minimum output is obtained at each test point and phase is the same for both L and R channels.

Step	Adjustment Items	Mode	Adjustment Parts	Test Points	Connection	Remarks
13	REC EQ Peak	REC/PLAY T. Select: METAL	L5503 VR5801 } (L) VR5803 } L5504 VR5802 } (R) VR5804 }	TP5501(L) TP5502(R) TP5001	Figure 23	 <ul style="list-style-type: none"> ● TEST TAPE: BLANK TAPE 1. Disconnect REC HEAD from connector (CB5101). 2. Connect TP5001 to chassis ground: BIAS OFF. 3. AF OSC: 200 Hz, 0 dBV input. Adjust VR5801, 5802 so that -10 dBV is obtained at each test point. 4. Set VR5803, 5804 to max. position. 5. AF OSC: 23 KHz, -20 dB input. Adjust maximum output is obtained at each test point and phase is the same for both L and R channels.
14	BIAS (1) OSC frequency (ERASE)	REC/PLAY T. Select: METAL	L5103	TP5104 TP5105	Figure 25	<ul style="list-style-type: none"> ● TEST TAPE: BLANK TAPE Adjust to obtain frequency reading of 112.64 KHz at test point. The output level under this conditions should be approx. 55 ~ 70mV (108 ~ 137mA) Voltage at TP5103 approx. METAL 8.5V
	(2) BIAS OSC Voltage Temporarily setting	REC/PLAY		TP5101(L) TP5102(R)		<ul style="list-style-type: none"> ● TEST TAPE: BLANK TAPE Check oscillator frequency set in step 14 (1).
		T. Select	L, R			Voltage at TP5101, 5102 approx.
METAL		VR5005, 5006		2.8V		
CrO ₂		VR5003, 5004		1.4V		
	NORMAL	VR5001, 5002		1.1V		
(3) Bias OSC	REC/PLAY T. Select: METAL	L5101 (L) L5102 (R)	TP5121(L) TP5122(R)	Figure 25	<ul style="list-style-type: none"> ● TEST TAPE: BLANK TAPE Connect oscilloscope to emitter of Q5103, 5104 and adjustment to obtain scope display shown below with maximum amplitude across test points.  <p>Emitter output voltage wave forms of Q5103, 5104.</p> <p>If the frequency has been upset, proceed steps 14 (1) ~ (2).</p>	

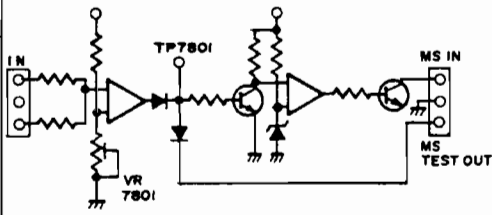
Step	Adjustment Items	Mode	Adjustment Parts	Test Points	Connection	Remarks		
15	Record/ Playback Level	REC PLAY		LINE OUT	Figure 27	1. Bias AF OSC: 400 Hz, 135mV (Dolby Level) Input. LINE OUT: 538mV (Tape position) Adjust Bias Adjust Volume so that Distortion Values shown in table below is obtained.		
						2. Level AF OSC: 400 Hz, -25 dB Input LINE OUT: 0 dB \approx 538mV Adjust level VR so that -25 dB is obtained in Tape position.		
						Tape Select /Reference Tape	1. Bias Distortion 0 dB \approx 538mV LINE OUT	2. Level LINE OUT (-25 dB)
						METAL AC712	Adjust VR5005, 5006 for 1.0%	VR5801, 5802 Source = Tape
						CrO ₂ AC512	Adjust VR5003, 5004 for 1.2%	VR5805, 5806 Source = Tape
						NORM AC223	Adjust VR5001, 5002 for 1.0%	VR5809, 5810 Source = Tape
						* If METAL bias is adjusted, always adjust bias for CrO ₂ and normal tapes. * Confirm REC CAL & BIAS controls are at center click position.		
		REC PLAY		LINE OUT	Figure 27	AF OSC: -25 dB Adjust respective trimming resistor so that record/playback frequency response with in the above limits (referred to 400 KHz) is obtained.		

Step	Adjustment Items	Mode	Adjustment Parts	Test Points	Connection	Remarks													
15	Record/ Playback Frequency Response					Adjustment Parts													
		T. Select				<table border="1"> <thead> <tr> <th>Reference Frequency</th> <th>Mid & Hi Frequencies</th> <th>High Frequencies</th> </tr> </thead> <tbody> <tr> <td>400 Hz L, R</td> <td>5 KHz L, R</td> <td>15K~20KHz L, R</td> </tr> </tbody> </table>	Reference Frequency	Mid & Hi Frequencies	High Frequencies	400 Hz L, R	5 KHz L, R	15K~20KHz L, R							
		Reference Frequency	Mid & Hi Frequencies	High Frequencies															
		400 Hz L, R	5 KHz L, R	15K~20KHz L, R															
		METAL AC712				<table border="1"> <tbody> <tr> <td>VR5801 VR5802</td> <td>VR5803 VR5804</td> <td>VR5005 VR5006</td> </tr> </tbody> </table>	VR5801 VR5802	VR5803 VR5804	VR5005 VR5006										
		VR5801 VR5802	VR5803 VR5804	VR5005 VR5006															
CrO ₂ AC512				<table border="1"> <tbody> <tr> <td>VR5805 VR5806</td> <td>VR5807 VR5808</td> <td>VR5003 VR5004</td> </tr> </tbody> </table>	VR5805 VR5806	VR5807 VR5808	VR5003 VR5004												
VR5805 VR5806	VR5807 VR5808	VR5003 VR5004																	
NORM AC223				<table border="1"> <tbody> <tr> <td>VR5809 VR5810</td> <td>VR5811 VR5812</td> <td>VR5001 VR5002</td> </tr> </tbody> </table>	VR5809 VR5810	VR5811 VR5812	VR5001 VR5002												
VR5809 VR5810	VR5811 VR5812	VR5001 VR5002																	
					<table border="1"> <thead> <tr> <th colspan="4">Procedure (Reference: Source)</th> </tr> <tr> <th></th> <th>400 Hz</th> <th>5 KHz</th> <th>15K ~ 20 KHz</th> </tr> </thead> <tbody> <tr> <td>METAL</td> <td rowspan="3">0 dB</td> <td rowspan="3">0 ~ +1 dB</td> <td rowspan="3">+3 dB</td> </tr> <tr> <td>CrO₂</td> </tr> <tr> <td>NORM</td> </tr> </tbody> </table> <p>* Repeatedly adjust for 5 KHz and 15K ~ 20 KHz.</p>	Procedure (Reference: Source)					400 Hz	5 KHz	15K ~ 20 KHz	METAL	0 dB	0 ~ +1 dB	+3 dB	CrO ₂	NORM
Procedure (Reference: Source)																			
	400 Hz	5 KHz	15K ~ 20 KHz																
METAL	0 dB	0 ~ +1 dB	+3 dB																
CrO ₂																			
NORM																			
16	Music Sensor Converter Voltage	CUE/ REVIEW	VR7801	TP7801	Figure 26														
						<ol style="list-style-type: none"> TEST TAPE: ITT-601 * 1 KHz -26 dB ON 60 sec. OFF 5 sec. Set unit to Cue/Review mode with a test tape loads. Precisely adjust following waveform is obtained at beginning of tape. <div style="text-align: center;">  </div> <ol style="list-style-type: none"> Check same waveform is obtained at near end of tape. The DC level is about 6V. After completion of adjustment, set MS COUNTER to 30° and all the tape run with MS mode and determine GO/NO with counted value at tape end. <p>* When making confirmation, move the tape in both direction. * Oscilloscope: 2V/cm DC Level Set</p>													

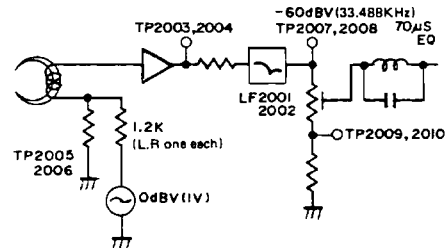
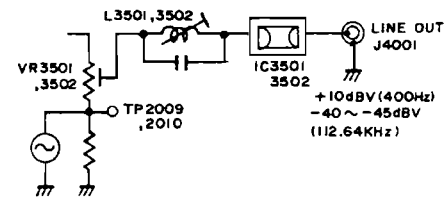

調整方法

手順	調整項目	モード	調整箇所	テストポイント	接続	備考												
1	ヘッド高さ チルト角度		ねじ A, B (16図)			<p>●測定ゲージ H-300</p> <ol style="list-style-type: none"> ヘッド高さ (17図) ガイドチェック棒がテープガイドをなめらかに通ること。 チルト角度 (18図) ガイドチェック棒がガイドプレートに対して平行になるかガイドチェック棒の頭が少し手前に傾くこと。 												
2	供給ピンチローラーの テープガイド		ねじ D (16図)			<p>●測定ゲージ H-300</p> ガイドチェック棒が供給ピンチローラーのテープガイドをなめらかに通ること。(17図)												
3	ヘッド アジマス	PLAY	ねじ C (16図)	TP3501(L) TP3502(R)	19図	<p>●テストテープ HTT-114 (10kHz)</p> 左右の出力が同相で最大、振幅が等しいこと。調整ねじを動かすすぎた時は、手順1のヘッド高さ、チルト角度調整を再び行うこと。												
4	テープの速度	PLAY	VR1	LINE OUT	20図	<p>●テストテープ HTT-111(3,000Hz)</p> ライン出力で、出力周波数が3,000+10,-0Hz になるようにVR1 を調整する。												
5	再生EQ, ピーク点	STOP T. Select: NORM	VR2001(L) VR2002(R)	TP2003(L) TP2004(R)	21図	<div style="text-align: center;"> </div> <ol style="list-style-type: none"> ブランクテープを入れて再生モードにする。 AF OSCより200Hz のテスト信号を入力し、テストポイントTP2003(TP2004)において 1.0V 出力 (=0dB) が得られるようにOSC 出力を調整する。 テスト信号周波数を(下表に示すように変えて対応する出力が得られるように調整する。(下表参照) <table border="1" style="margin-left: auto; margin-right: auto;"> <thead> <tr> <th></th> <th>確認</th> <th>確認</th> <th>調整</th> </tr> </thead> <tbody> <tr> <td>周波数 Hz</td> <td>20</td> <td>6K</td> <td>20K</td> </tr> <tr> <td>出力 dB</td> <td>11.5</td> <td>- 15.5</td> <td>- 12.0</td> </tr> </tbody> </table> <ol style="list-style-type: none"> メタル位置にした時6kHzで出力が -19.5dBになることを確認すること。 		確認	確認	調整	周波数 Hz	20	6K	20K	出力 dB	11.5	- 15.5	- 12.0
	確認	確認	調整															
周波数 Hz	20	6K	20K															
出力 dB	11.5	- 15.5	- 12.0															

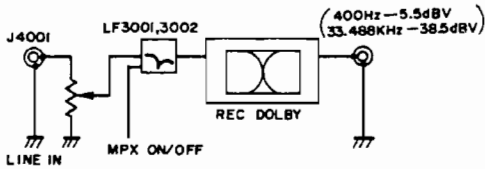
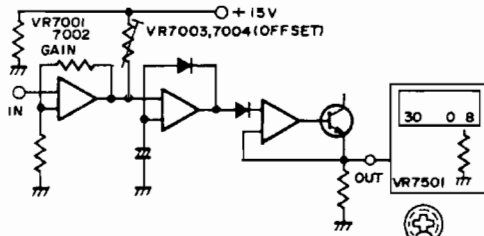
手順	調整項目	モード	調整箇所	テストポイント	接続	備考
6	再生 フィルター	STOP T. Select: NORM	LF2001(L) LF2002(R)	TP2007(L) TP2008(R)	21図	 <p>1. 手順5のセットのままにしておく。 AF OSC周波数を33.488kHzにしてテストポイントの出力が最小になること。また左右のチャンネルの位相が同じであること。</p>
7	再生バイアス トラップ	PLAY T. Select: NORM	L3501(L) L3502(R)	TP2009(L) TP2010(R) LINE OUT	22図	 <p>1. ブランクテープを入れて再生モードにする。 2. AF OSC: 400Hz ライン出力において +10dBが得られるようにVR3501, VR3502を調整する。 3. AF OSCより 112.64kHz信号を入力し同相で最小のライン出力になるように調整する。</p>
8	ドルビー レベル	PLAY T. Select: NORM NR:OFF	VR3501(L) VR3502(R)	TP3501(L) TP3502(R)	19図	テストテープ HTT-150(400Hz) それぞれのテストポイントで-10dBmの出力になるように調整する。
9	入力感度特性 レベル	STOP MONITOR: SOURCE	REC レベル ボリューム VR2301(L) VR2302(R)	TP3501(L) TP3502(R)	23図	AF OSC: 400Hz, 135mV ラインイン入力 それぞれのテストポイントで-10dBmの出力になるように調整する。

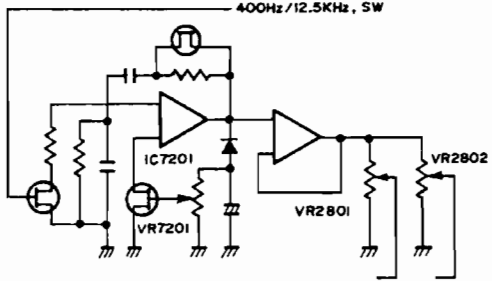
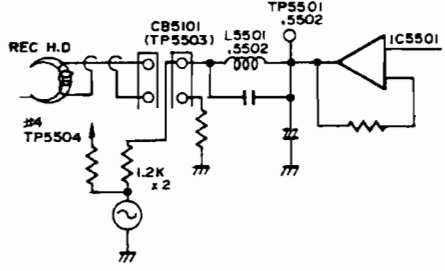
手順	調整項目	モード	調整箇所	テストポイント	接続	備考
10	MPX フィルター	STOP MONITOR SOURCE NR: OFF MPX SW: OFF	LF3001(L) LF3002(R)	LINE OUT	23図	 <ol style="list-style-type: none"> 1. AF OSC: 400Hz, 135mV ラインイン入力 2. ライン出力が538mV=0dB(標準)であることを確認する。 3. AF OSC出力周波数を33.487kHzにし、ライン出力が最小で左右のチャンネルが同相になるように調整すること。 4. MPX をオン、AF OSCを19kHzにする。 ライン出力レベルが30dB以上減ることを確認すること。そうならない場合は、手順2にもどり33.488kHzの周波数を他の周波数に換え30dB減るように調整する。この時、左右のチャンネルは同相であること。
11	(1) レベル メーター 調整	STOP MONITOR: SOURCE NR: OFF TEST TONE: OFF	VR7001(L) VR7002(R) VR7003(L) VR7004(R) VR7501	FLメーター	23図	 <ol style="list-style-type: none"> 1. AF OSC: 400Hz, 135mV(ドルビーレベル入力) 2. VR7501をメカニカルセンターに合わせる。 3. レベルメーターの 0~+1の点が点灯するように VR7001, VR7002 を調整する。 4. AF OSC: オシレーターの出力を27dB減らす。 5. レベルメーターの30~20の点が点灯するように VR7003, VR7004 を調整する。 6. AF OSC: オシレーターの出力を27dB減らす。 7. レベルメーターの30~20の点が消灯するように VR7003, VR7004 を調整する。 8. 変化がなくなるまで上の手順を繰り返す。

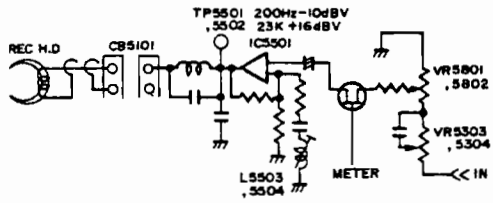
手順	調整項目	モード	調整箇所	テストポイント	接続	備考
	(2) トーン OSC レベル	STOP MONITOR: SOURCE NR:OFF TEST TONE: REC CAL: BIAS	VR7201 VR2801(L) VR2802(R)	FLメーター LINE OUT	23図	 <ol style="list-style-type: none"> 1. VR7201を最小の位置に合わせる。 2. レベルメーターの 0~+1の点が点灯するように VR2801, VR2802 を調整する。 3. テストトーンスイッチをREC CAL 位置にしてライン出力レベルを確認する。 4. テストトーンスイッチをバイアス位置にしてライン出力レベルが、REC CAL 位置の時と同じ値であることを確認する。 また、レベルメーターがREC CAL 位置の時と同じ値であることを確認する。
12	REC バイアス トラップ	REC/PLAY T. Select: METAL	L5501(L) L5502(R)	TP5501 (L) TP5503 (L) (CB5101, #1) TP5502 (R) TP5504 (R) (CB5101, #4) TP5001	24図	 <p>●テストテープ：ブランクテープ</p> <ol style="list-style-type: none"> 1. REC HEADをコネクターからはずす。 (CB5101) 2. TP5001をシャーシに接続する。 BIAS:OFF 3. AF OSC: 112.64kHz, 0dBV 入力 それぞれのテストポイントで最小出力が得られ、左右のチャンネルで同じ位相になるように調整する。

手順	調整項目	モード	調整箇所	テストポイント	接続	備考				
13	REC EQ ピーク	REC/PLAY T. Select: METAL	L5503 VR5801 VR5803 (L) L5504 VR5802 (R) VR5804	TP5501(L) TP5502(R) TP5001	23図	 <p>●テストテープ：ブランクテープ</p> <ol style="list-style-type: none"> REC HEADをコネクターからはずす。 (CB5101) TP5001をシャーシアースに接続する。 BIASはOFF AF OSC: 200HZ, 0dB 入力 それぞれのテストポイントで-10dBVが得られるようにVR5801, 5802 を調整する。 VR5803, 5804 を最大にする。 AF OSC: 23KHZ, -20dB入力 それぞれのテストポイントで最大出力が得られ、左右のチャンネルが同じ位相になるように調整する。 				
14	バイアス (1) OSC 周波数 (ERASE)	REC/PLAY T. Select: METAL	L5103	TP5104 TP5105	25図	<p>●テストテープ ブランクテープ</p> <p>テストポイントにおいて 112.64kHzの周波数が得られるように調整する。この時の出力レベルは約55~70mV (108~137mA)であること。 TP5103における電圧はメタルで約 8.5V。</p>				
	(2) バイアス OSC 電圧 暫定調整	REC/PLAY T. Select METAL CrO2 NORMAL	L, R VR5005, 5006 VR5003, 5004 VR5001, 5002	TP5101(L) TP5102(R)		<p>●テストテープ ブランクテープ</p> <p>手順14(1) で合わせたオシレーターの周波数を確認する。</p> <table border="1" data-bbox="866 1272 1511 1411"> <tr> <td>TP5101, 5102における電圧</td> </tr> <tr> <td>約 2.8V</td> </tr> <tr> <td>約 1.4V</td> </tr> <tr> <td>約 1.1V</td> </tr> </table>	TP5101, 5102における電圧	約 2.8V	約 1.4V	約 1.1V
	TP5101, 5102における電圧									
約 2.8V										
約 1.4V										
約 1.1V										
(3) バイアス OSC	REC/PLAY T. Select: METAL	L5101(L) L5102(R)	TP5121(L) TP5122(R)	<p>●テストテープ ブランクテープ</p> <p>Q5103, 5104 のエミッターにオシロスコブを接続する。テストポイント間の振幅が最大で、スコープの表示が下のようになるよう調整すること。</p>  <p>Q5103, 5104 のエミッター出力電圧波形 周波数が合っていない時は手順14(1) ~ (2) を行う。</p>						

手順	調整項目	モード	調整箇所	テストポイント	接続	備考		
15	録音／再生レベル	REC PLAY		LINE OUT	27図	1. バイアス AF OSC: 400HZ, 135mV (ドルビーレベル) 入力。 ラインアウト: 538mV (テープ位置) 下表の示すバイアス歪み値になるようにバイアス調整ボリュームを調整する。 2. レベル AF OSC: 400HZ, -25dB入力 ラインアウト: 0dB (538mV) テープ位置にして-25dB が得られるようにレベルVRを調整する。		
						テープ選択／標準テープ	1. バイアス歪み 0dB=538mV ラインアウト	2. レベル ラインアウト (-25dB)
						メタル AC712	1.0% になるようにVR5005, 5006を調整	VR5801, 5802 SOURCE: テープ
						クロム AC512	1.2% になるようにVR5003, 5004を調整	VR5805, 5806 SOURCE: テープ
						ノーマル AC 223	1.0% になるようにVR5001, 5002を調整	VR5809, 5810 SOURCE: テープ
						<ul style="list-style-type: none"> * メタルバイアスを調整する時は、クロムテープ、ノーマルテープのバイアスも調整すること。 * REC CAL とバイアスコントロールが中心位置にあることを確認する。 		
録音／再生周波数特性	録音／再生周波数特性	REC PLAY		LINE OUT	27図	AF OSC: -25dB 録音／再生周波数特性が範囲内であるようにそれぞれの半固定抵抗を調整する。		
						T. Select	調整箇所	
		標準周波数 400HZ L, R	中域周波数 5kHz L, R	高域周波数 15k ~20kHz L, R				
	メタル AC712	VR5801 VR5802	VR5803 VR5804	VR5005 VR5006				
	クロム AC512	VR5805 VR5806	VR5807 VR5808	VR5003 VR5004				
	ノーマル AC223	VR5809 VR5810	VR5811 VR5812	VR5001 VR5002				
		手順 (標準: SOURCE)						
		400HZ	5kHz	15k ~20kHz				
	メタル	0dB	0~+1dB	+3dB				
	クロム							
	ノーマル							
<ul style="list-style-type: none"> * 5kHzと15~20kHzになるように調整を繰り返す。 								

手順	調整項目	モード	調整箇所	テストポイント	接続	備考
16	ミュージック センサー コンバーター 電圧	CUE/REVIEW	VR7801	TP7801	26図	<p>1. テストテープ [IT-601 * 1KHZ -26dB ON 60秒 OFF 5秒</p> <p>2. テストテープを入れてキュー／レビューモードにする。</p> <p>3. テープの始めで次の波形になるように調整する。</p> <p>4. テープの終り近くで同じ波形になるように調整する。 DCレベルは約6V。</p> <p>5. 調整が終わったら、HSカウンターを30°にし、テープをHSモードで走行させ、テープの終りのカウンターの値で良いか悪いかが決める。</p> <p>* 確認を行う時はテープを両方向に走らせること。</p> <p>* オシロスコープ：2V/cm DCレベル</p>

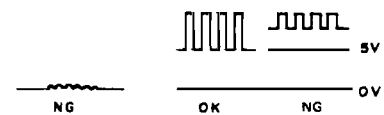
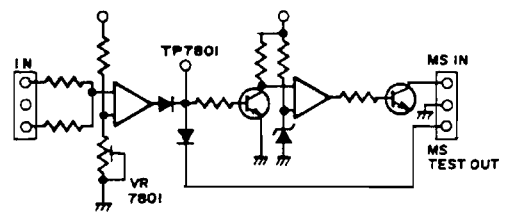

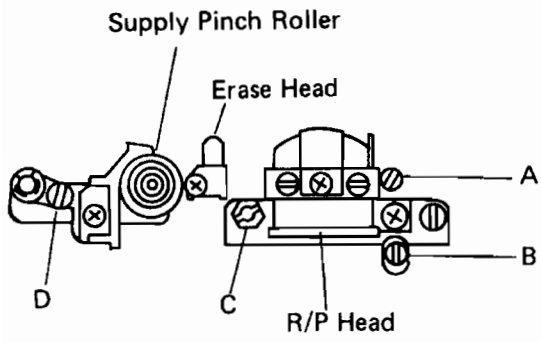

Figure 16

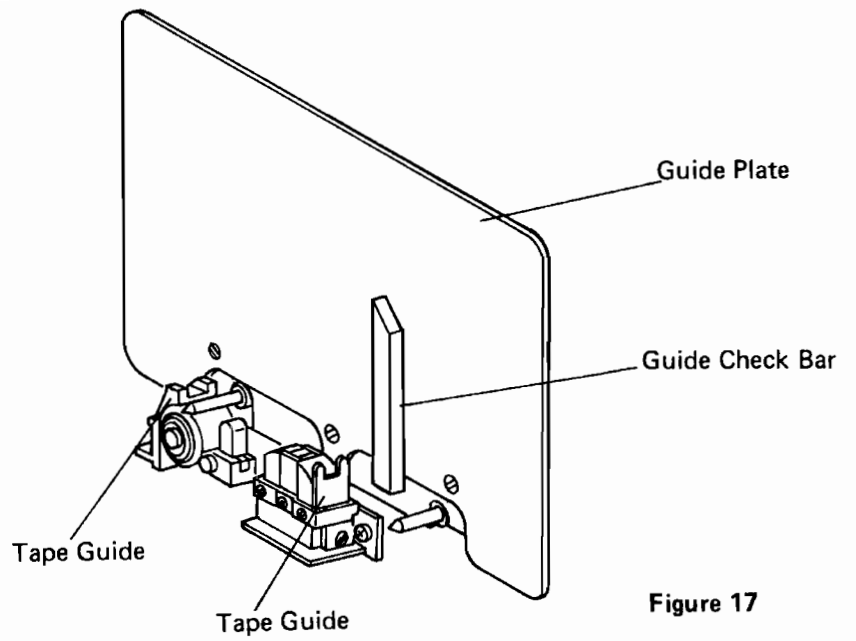

Figure 17

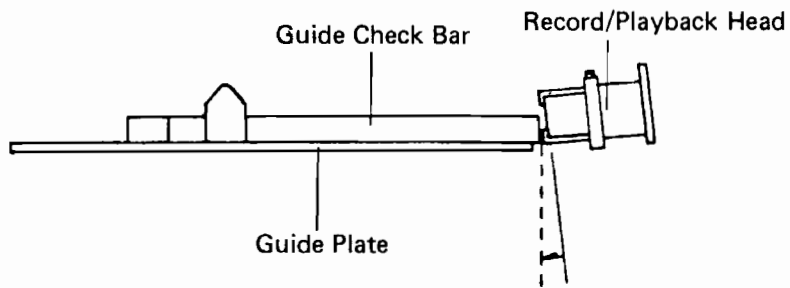

Figure 18

CONNECTION DIAGRAMS

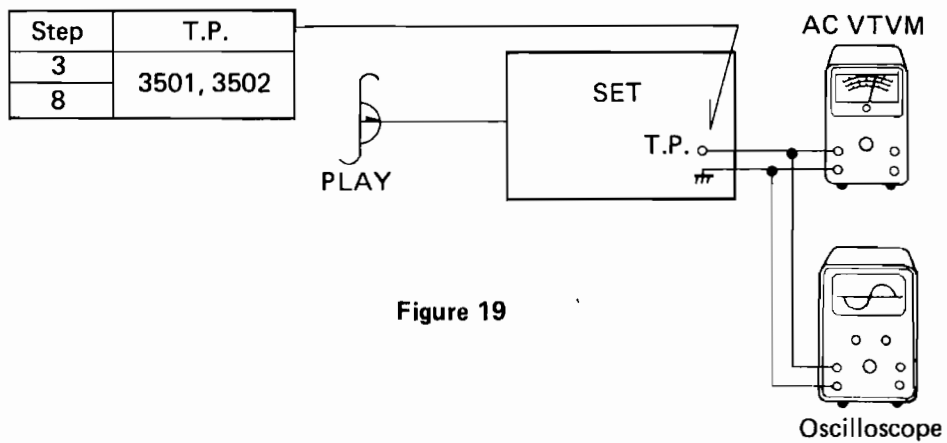

Figure 19

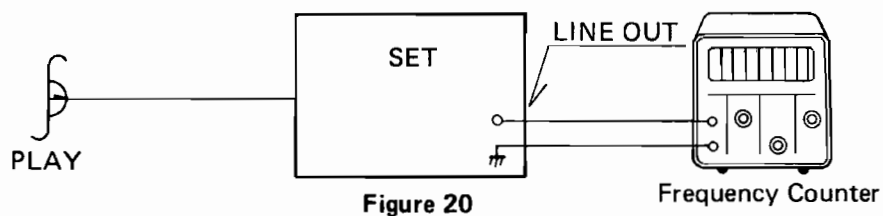

Figure 20

STEP	T.P.
5	2003, 2004
6	2007, 2008

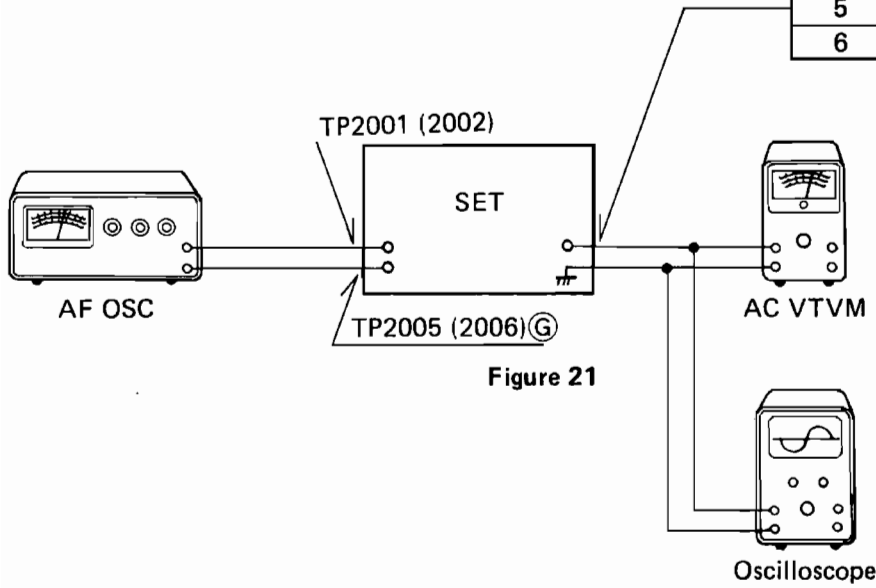

Figure 21

Step	T.P.
7	2009, 2010
10	LINE IN

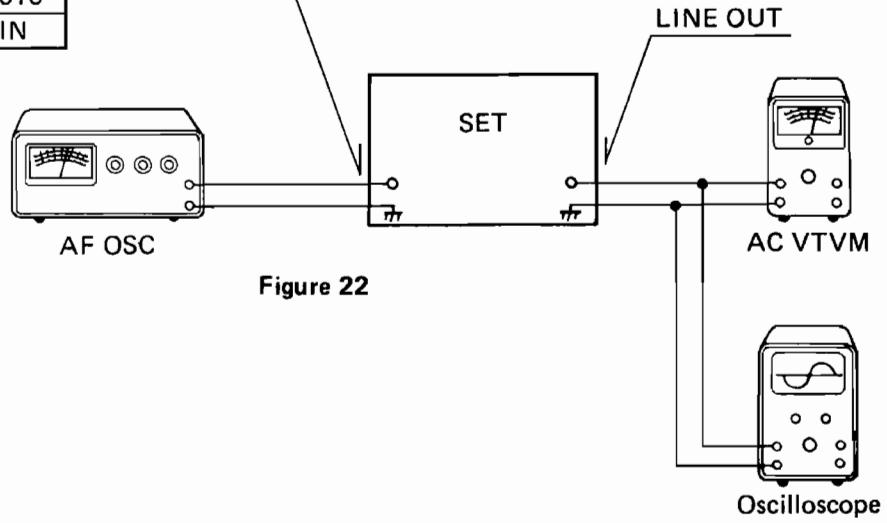

Figure 22

Step	T.P.
9, 11	3001, 3002
13	5501, 5502

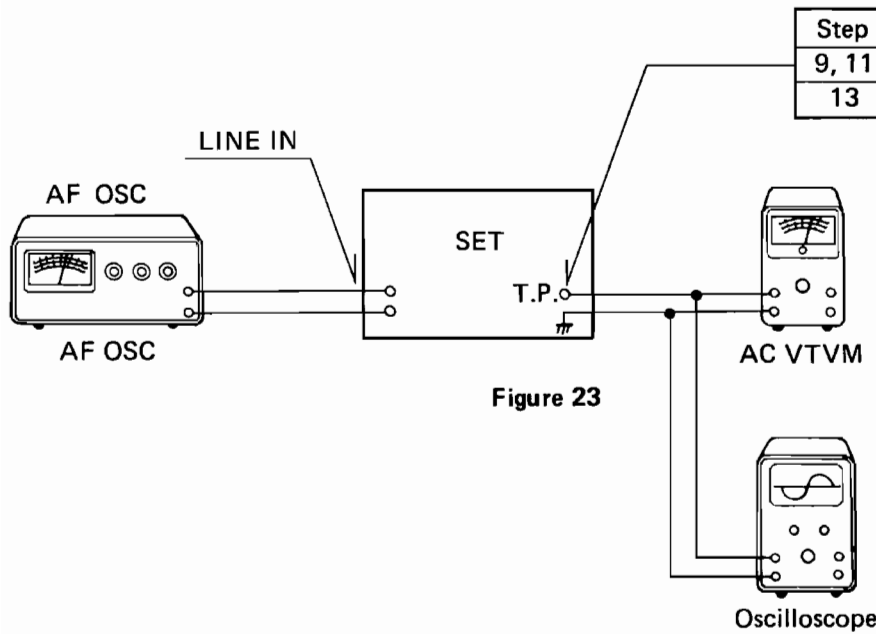

Figure 23

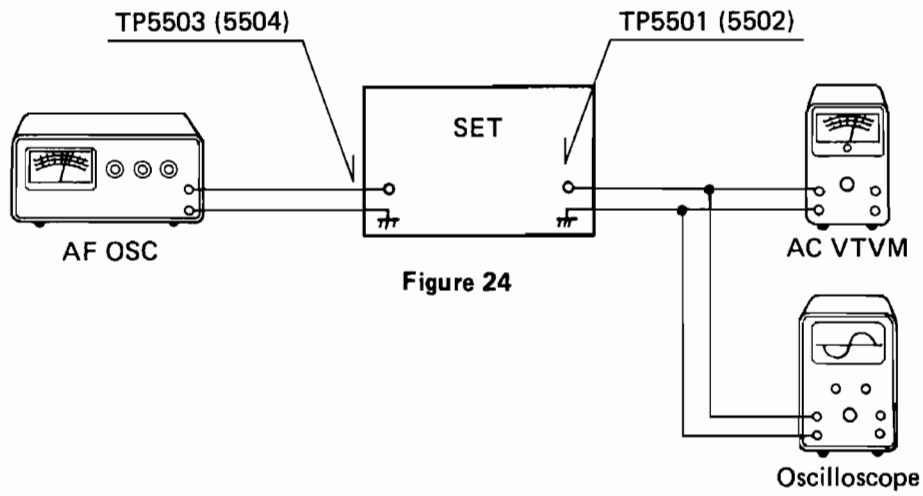

Figure 24

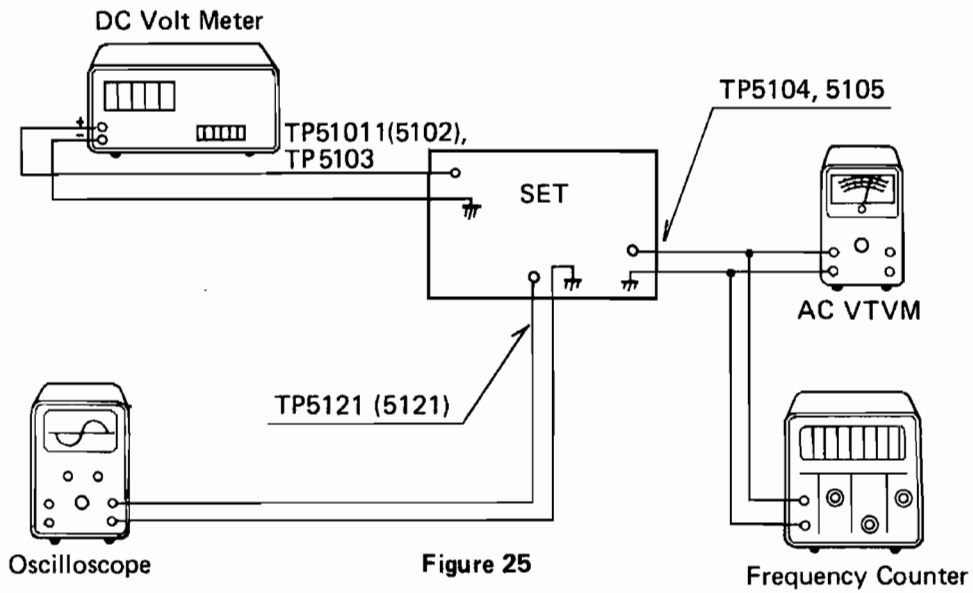

Figure 25

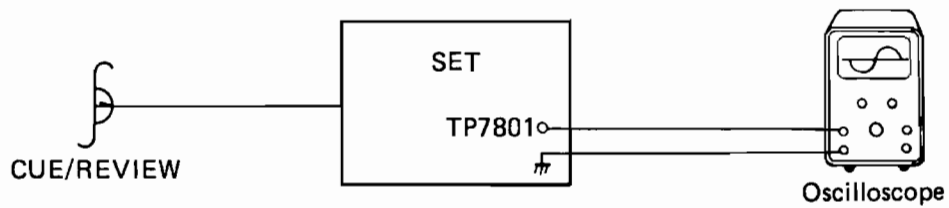

Figure 26

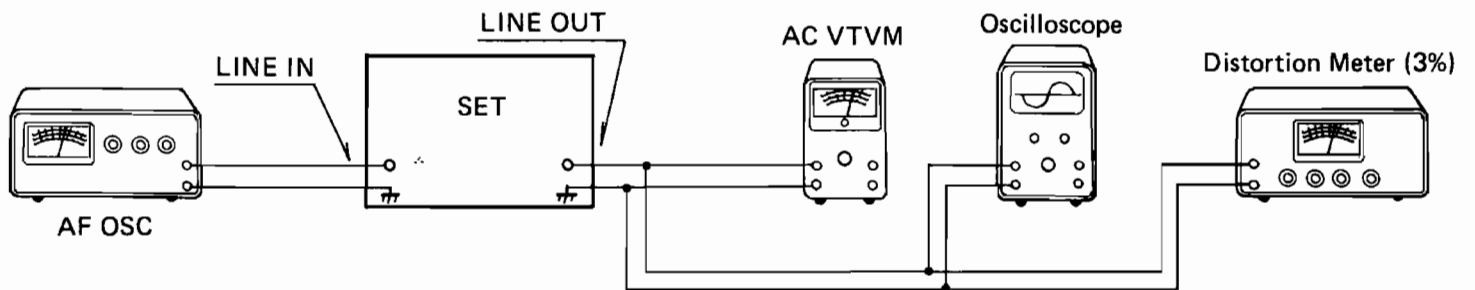
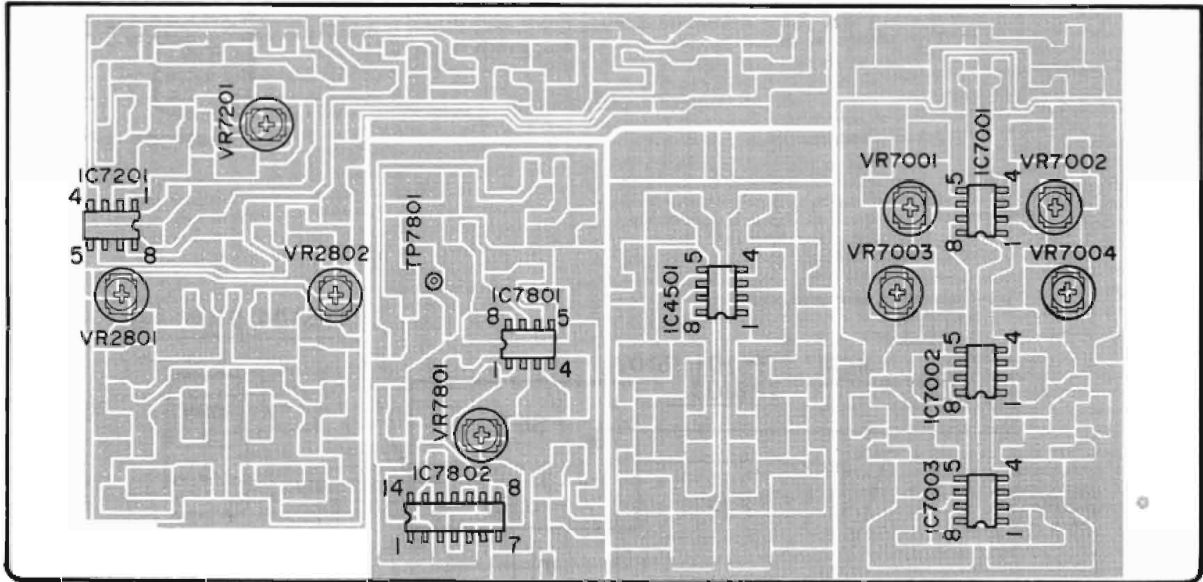
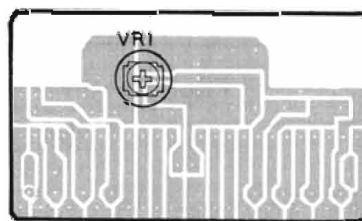

Figure 27

Adjustment Locations



Test Tone P.C. Board



Wire Assembly P.C. Board

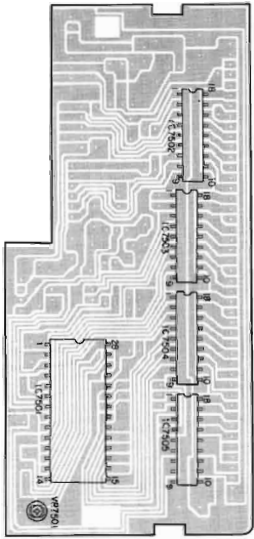

FL Meter P.C. Board

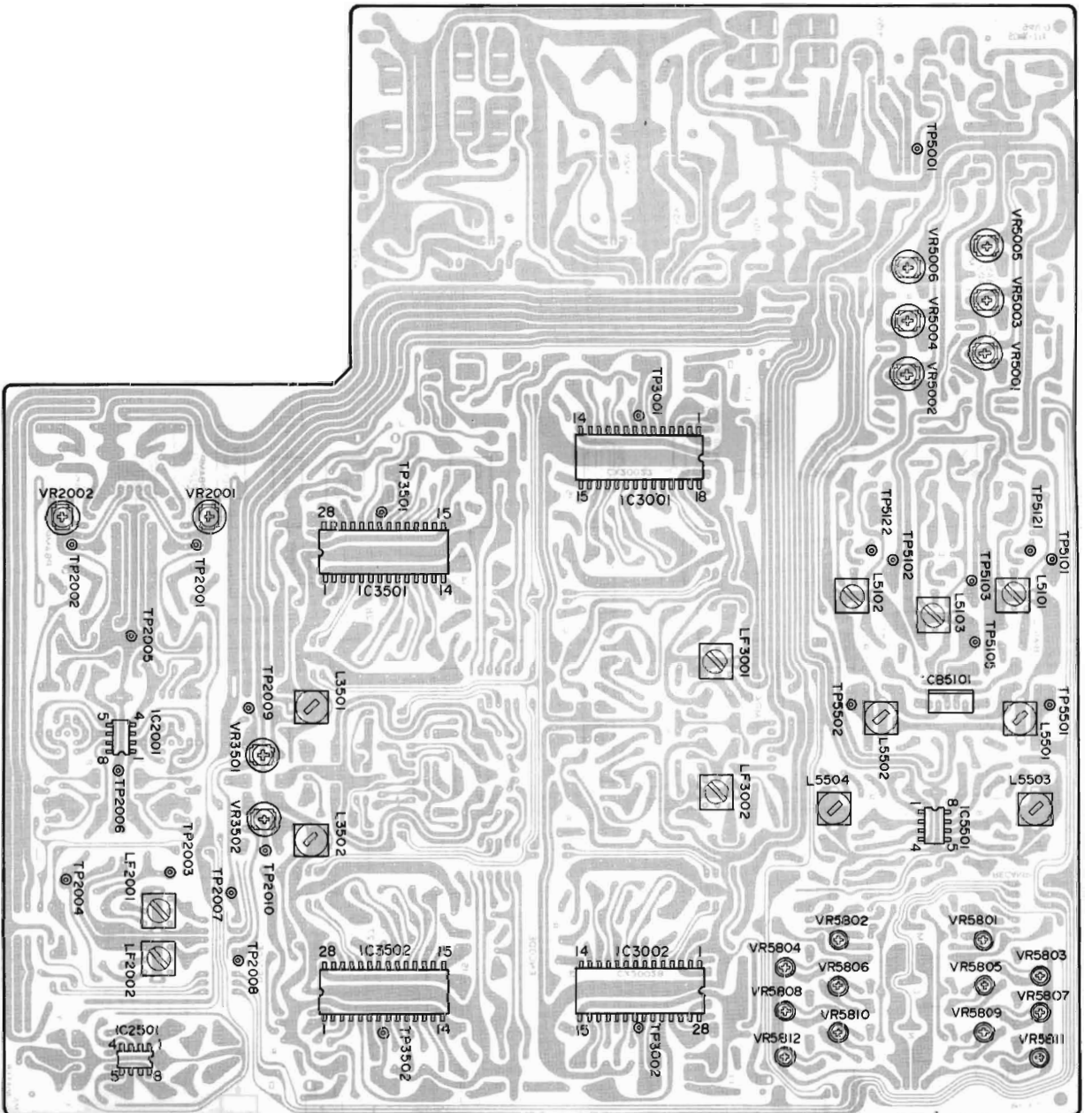

Mother P.C. Board

Block Diagram

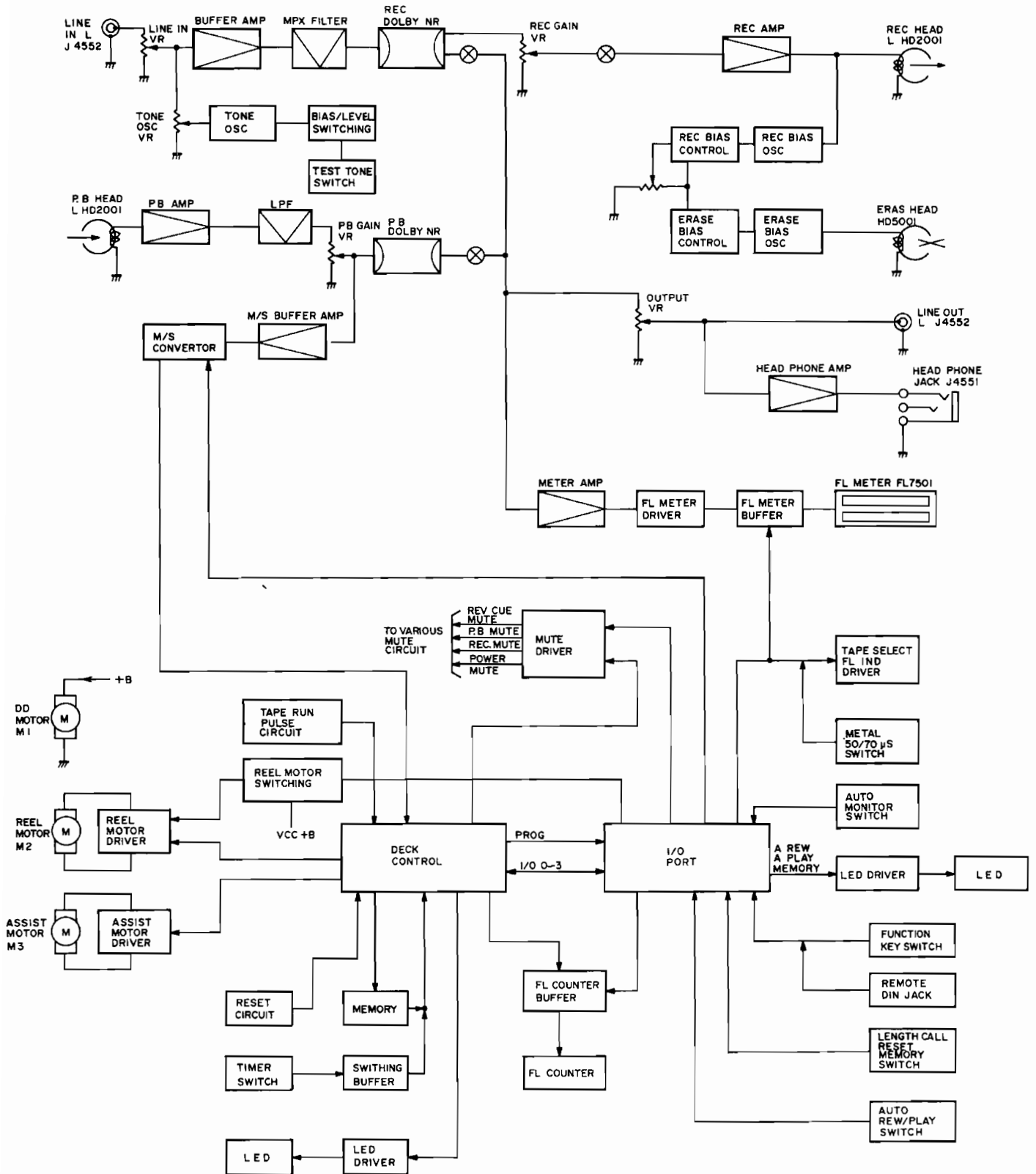

Replacement of Mechanical Parts

1. Replacement of Cassette Deck Assembly

- (1) Remove the cassette deck assembly according to the item "Parts Locations and Instructions".
- (2) After replacing the cassette deck assembly with a new one, assemble the unit in the reverse way to disassembly.

2. Replacement of Record/Playback and Erase Heads

- (1) Remove the cassette deck assembly according to the item "Parts Locations and Instructions".
- (2) For removal of the record/playback head, remove two screws (A) and disconnect the lead wires from the head P.C. Board as shown in Figure 28. Then remove the record/playback head from the P.C. Board using a soldering iron.

For removal of the erase head, remove the screw (B) and disconnect the lead wires from the head to take it off as shown in Figure 28.

- (3) After replacing the head(s) with a new one and installing the head in the reverse way to disassembly, adjust head azimuth, height and tilt angle.
- (4) Apply a lock paint on the screws (A, B) after mechanical adjustment and readjust electrical adjustment according to "Adjustment Procedures".

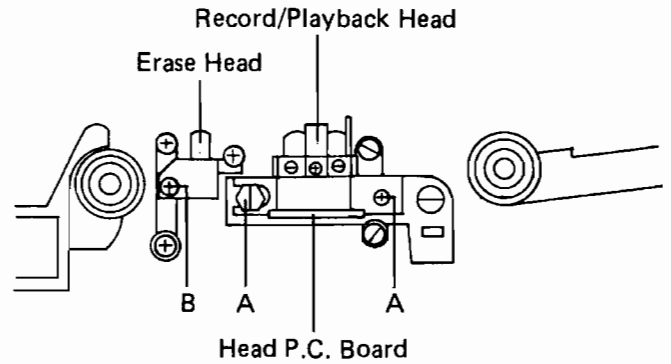

Figure 28

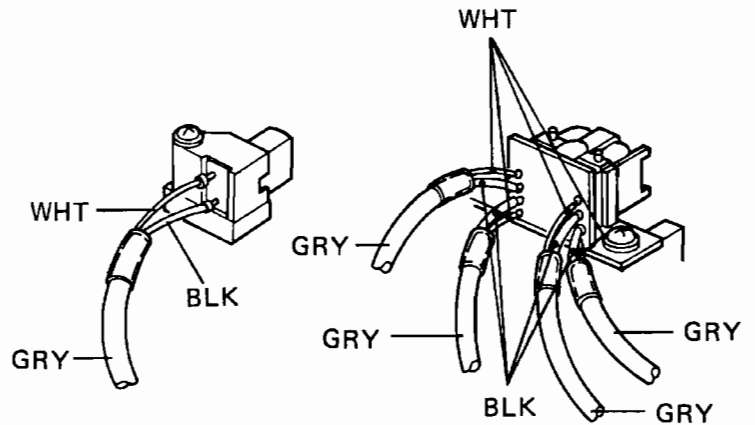

Figure 29

3. Replacement of Pinch Roller Assembly (S)

- (1) Remove the cassette deck assembly.
- (2) Remove the "E" ring to take off the pinch roller assembly (S) as shown in Figure 30.
- (3) After replacing the pinch roller assembly (S) with a new one, clean it with absolute alcohol and assemble it in the reverse way to the disassembly.
- (4) After assembling, confirm tape speed and wow/flutter are suitable according to "Adjustment Procedures".

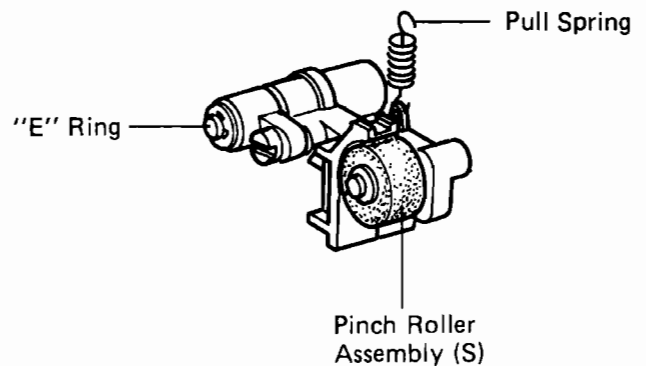

Figure 30

4. Replacement of Pinch Roller Assembly (T)

- (1) Remove the cassette deck assembly and then the dust cover assembly.
- (2) Remove the pull spring and the "E" ring to take off the pinch roller assembly as shown in Figure 31.
- (3) After replacing the pinch roller assembly (T) with a new one, clean it with absolute alcohol and assemble it in the reverse way to the disassembly.
- (4) After assembling, confirm tape speed and wow/flutter are suitable according to "Adjustment Procedures".

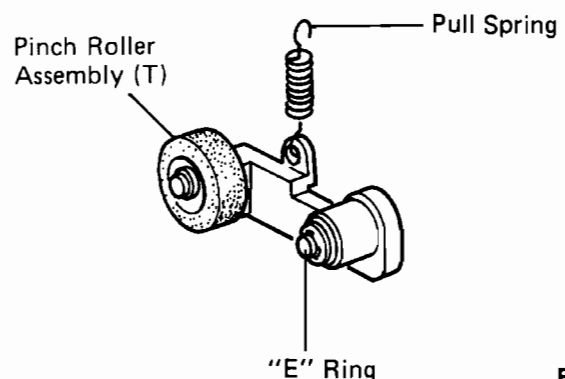

Figure 31

5. Replacement of Drive Motor Assembly

- (1) Remove the cassette deck assembly.
- (2) Remove two screws (●) as shown in Figure 32. and two lead wires (violet, orange) from the wire assembly P.C. Board.
- (3) After replacing the drive motor assembly with a new one, assemble it in the reverse way to disassembly.
- (4) After assembling, confirm tape speed and wow/ flutter are suitable according to "Adjustment Procedures".

6. Replacement of Drive Belt

- (1) Remove the cassette deck assembly.
- (2) Remove a screw (○) as shown in Figure 32.
- (3) After replacing the drive Belt with a new one assemble it in the reverse way to disassembly.
- (4) After assembling, confirm tape speed and wow/ flutter are suitable according to "Adjustment Procedures".

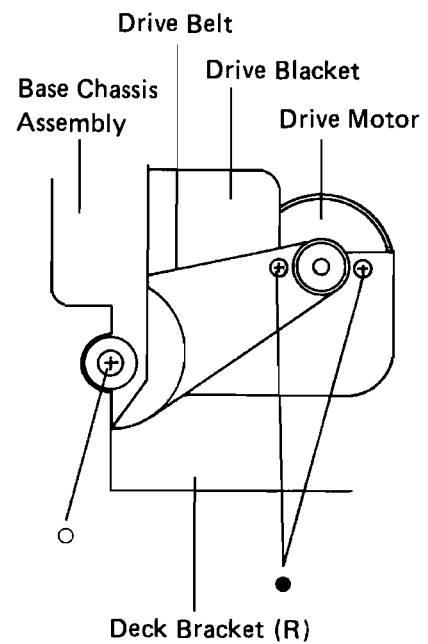

Figure 32

機構部品の交換

1. カセットデッキ組立の交換

- (1) 「各部の名称と説明」の項を参照して、カセットデッキ組立をはずします。
- (2) 新しいカセットデッキに交換し、はずした時と逆の順に取り付けます。

2. 録音／再生ヘッド、消去ヘッドの交換

- (1) 「各部の名称と説明」の項を参照して、カセットデッキ組立をはずします。
- (2) 2個のねじ (A) をはずし、ヘッドP.C.板からリード線ははずします (28図参照)。ハンダごてを使ってヘッドP.C.板から録音／再生ヘッドをはずします。1個のねじ (B) をはずし、消去ヘッドからリード線ははずすと、消去ヘッドははずれます (29図参照)。
- (3) 新しいヘッドに交換し、はずした時と逆の順に取り付けます。そして、ヘッドアジマス、高さ、チルト角度を調整します。
- (4) 機構調整の後、ねじ (A, B) にロックバイントを塗布し、「調整方法」を参照して電気調整をします。

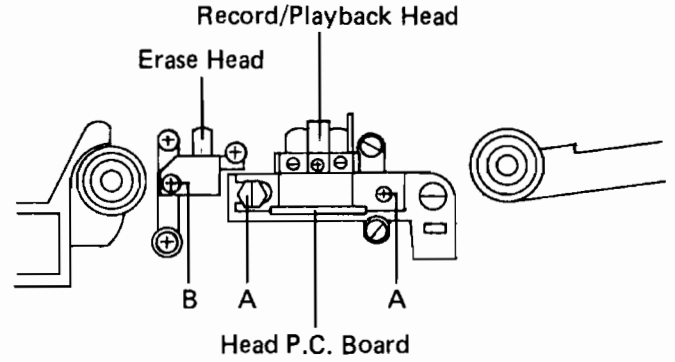

Figure 28

3. ピンチローラー組立 (S) の交換

- (1) カセットデッキ組立をはずします。
- (2) Eリングをはずすと、ピンチローラー組立 (S) ははずれます (30図参照)。
- (3) 新しいピンチローラー組立 (S) に交換した後、無水アルコールでピンチローラー組立を清掃し、はずした時と逆の順に取り付けます。
- (4) 取り付けた後、「調整方法」の項を参照しテープ速度とワウ・フラッターが適当かどうか確認します。

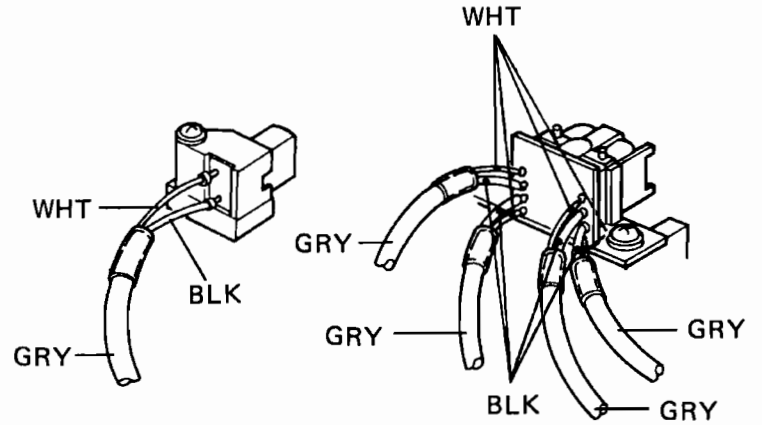

Figure 29

4. ピンチローラー組立 (T) の交換

- (1) カセットデッキ組立とダストカバー組立をはずします。
- (2) スプリングとEリングをはずすと、ピンチローラー組立ははずれます (31図参照)。
- (3) 新しいピンチローラー組立 (T) に交換した後、無水アルコールでピンチローラー組立を清掃し、はずした時と逆の順に取り付けます。
- (4) 取り付けた後、「調整方法」の項を参照し、テープ速度とワウ・フラッターが適当かどうか確認します。

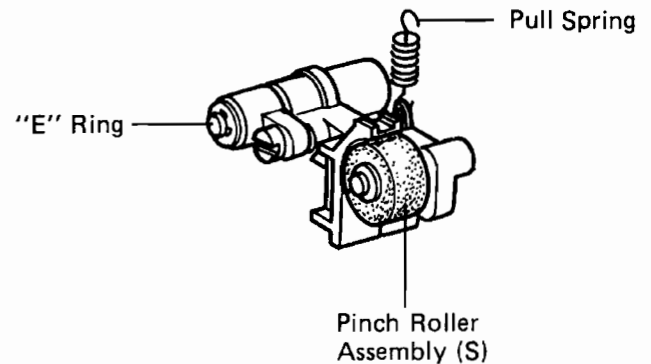

Figure 30

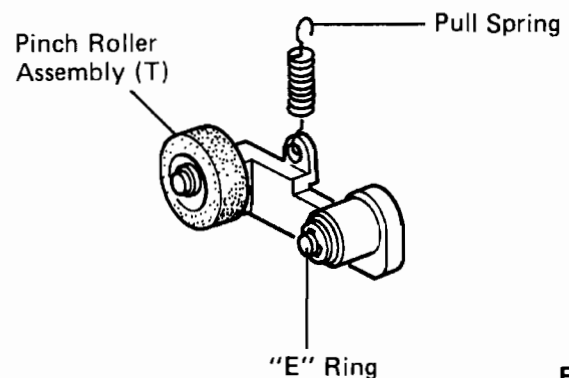

Figure 31

5. ドライブモーター組立の交換

- (1) カセットデッキ組立をはずします。
- (2) 2個のねじ●印をはずし、ワイヤー組立PC板から2本のリード線(紫, 橙)をはずします(32図参照)。
- (3) 新しいドライブモーターに交換し, はずした時と逆の順に取り付けます。
- (4) 取り付け後, 「調整方法」の項を参照しテープ速度とワウ・フラッターが適当かどうか確認します。

6. ドライブベルトの交換

- (1) カセットデッキ組立をはずします。
- (2) 1個のねじ○印をはずします(32図参照)。
- (3) 新しいドライブベルトに交換し, はずした時と逆の順に取り付けます。
- (4) 取り付け後, 「調整方法」の項を参照し, テープ速度とワウ・フラッターが適当かどうか確認します。

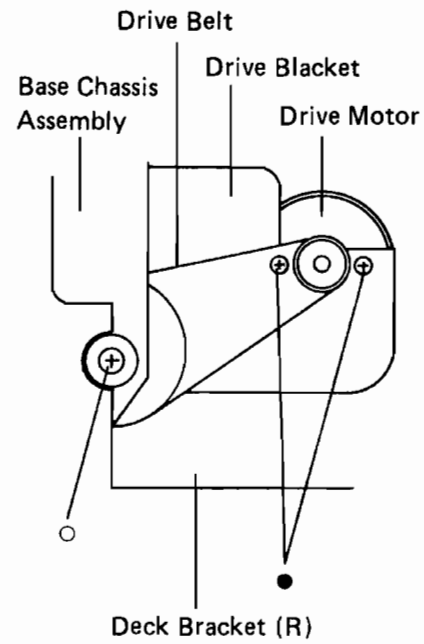

Figure 32

Trouble Shooting Guide

When the tape deck fails to function properly, check following conditions first, then examine it according to the check list below.

1. Are all connections correct?

2. Is this unit properly used as instructed in the manual?

3. Is there any trouble on speakers and amplifiers?

Symptom	Causes	Remedy
<ul style="list-style-type: none"> ● Tape does not run. 	<ul style="list-style-type: none"> ● No power supplied. ● Cassette door is not properly closed. ● PAUSE switch was touched and the deck is in pause mode. ● Tape end is reached. 	<ul style="list-style-type: none"> ● Check AC supply cord and POWER switch. ● Push EJECT knob to check cassette loading and close the cassette door again. ● Release the pause mode. ● Rewind the tape or turn the cassette over.
<ul style="list-style-type: none"> ● During rewind, the tape stops or goes into playback. 	<ul style="list-style-type: none"> ● MEMORY or AUTO PLAY function is actuated. 	<ul style="list-style-type: none"> ● Clear memory by pushing RESET & CAL switches and push AUTO PLAY switch to release the AUTO PLAY mode.
<ul style="list-style-type: none"> ● Recording is not possible. 	<ul style="list-style-type: none"> ● Tabs for prevention of accidental erasure have been removed. ● Connections are improper. ● Heads are dirty. 	<ul style="list-style-type: none"> ● Cover the tab openings with a piece of adhesive tape. ● Check connections. ● Perform head cleaning.
<ul style="list-style-type: none"> ● No playback sound. 	<ul style="list-style-type: none"> ● During playback, AUTO MONITOR switch is set to SOURCE. ● OUTPUT LEVEL control is set to minimum. 	<ul style="list-style-type: none"> ● Set AUTO MONITOR switch to TAPE. ● Adjust for proper level.
<ul style="list-style-type: none"> ● Recording or playback operation starts automatically when power is switched on. 	<ul style="list-style-type: none"> ● TIMER switch is not set to OFF. 	<ul style="list-style-type: none"> ● Set TIMER switch to OFF.
<ul style="list-style-type: none"> ● Input signal does not come in the deck when recording. 	<ul style="list-style-type: none"> ● REC LEVEL controls are set to minimum. ● Connections between AL-81 and stereo system are incorrect. 	<ul style="list-style-type: none"> ● Adjust for proper level. ● Check connections and cords.
<ul style="list-style-type: none"> ● Playback sound is husky or left/right sound balance is instable. 	<ul style="list-style-type: none"> ● Heads are dirty. ● Tape is stretched or warped. 	<ul style="list-style-type: none"> ● Perform head cleaning. ● Use another tape.
<ul style="list-style-type: none"> ● Excessive tape hiss. 	<ul style="list-style-type: none"> ● Heads are magnetized. ● Inferior tape with high hiss noise is used. ● Heads are dirty. ● Setting of DOLBY NR C/B or ON/OFF switches are unsuitable. ● Recording level is too low. 	<ul style="list-style-type: none"> ● Perform head demagnetizing. ● Replace the tape. ● Perform head cleaning. ● Set the switch to a correct position. ● Adjust for proper level.
<ul style="list-style-type: none"> ● Sound is distorted. 	<ul style="list-style-type: none"> ● Recorded sound on the tape itself is distorted. ● Recording level is too high. 	<ul style="list-style-type: none"> ● Check by listening to another tape. ● Adjust for proper level.

Symptom	Causes	Remedy
<ul style="list-style-type: none"> Wow/flutter is excessive and sound intermittent. 	<ul style="list-style-type: none"> Heads, pinch rollers and capstans are dirty. Tape is wound too tightly or unevenly. 	<ul style="list-style-type: none"> Perform cleaning of heads and tape transport part. Wind the tape with fast forward or rewind.
<ul style="list-style-type: none"> Loud hum noise is heard during playback. 	<ul style="list-style-type: none"> Connection cords are not plugged in correctly. External leakage flux (in inductive fields from amplifier power transformer, etc.) occurs. Heads are dirty. 	<ul style="list-style-type: none"> Securely plug in all cords. Remove inductive sources such as fluorescent lamps, amplifiers, transformers, etc. from the vicinity of the deck. Perform head cleaning.
<ul style="list-style-type: none"> High tone is excessively enhanced. 	<ul style="list-style-type: none"> DOLBY NR system is not engaged properly. 	<ul style="list-style-type: none"> DOLBY NR system as was used in recording must be employed for playback.
<ul style="list-style-type: none"> High tone is weak. 	<ul style="list-style-type: none"> Heads are dirty. Dolby NR system is engaged for playback of a tape which was not recorded with Dolby NR system. 	<ul style="list-style-type: none"> Perform head cleaning. Set DOLBY NR select switch to OFF.
<ul style="list-style-type: none"> Only timer playback is effective even if the deck is set up for timer recording. 	<ul style="list-style-type: none"> Tabs for prevention of accidental erasure have been removed. 	<ul style="list-style-type: none"> Cover the tab opening with a piece of adhesive tape.
<ul style="list-style-type: none"> Calibration adjustment is impossible. 	<ul style="list-style-type: none"> Extremely worn-out tape is used. Heads are dirty. 	<ul style="list-style-type: none"> Use the another cassette tape. Perform head cleaning.
<ul style="list-style-type: none"> Counter memory operation can not be performed. 	<ul style="list-style-type: none"> MEMORY switch is set to OFF. 	<ul style="list-style-type: none"> Set MEMORY switch to ON.

トラブルシューティング

テープデッキが正常に動かなくなったら、次の条件を満たしているかどうかをまず確認してから、下のチェックリストに従って調べます。

1. 接続はきちんとされていますか？
2. マニュアルの説明通りに使用していますか？
3. スピーカーやアンプに故障はありませんか？

症状	原因	処置
* テープが動かない。	* 電源がはいっていない。 * カセット蓋がきちんと閉まっていない。 * ポーズスイッチが押されているため、ポーズモードになっている。 * テープが終りにになっている。	* ACコードと電源スイッチを確認。 * イジェクトボタンを押して再びカセット蓋を閉める。 * ポーズモードを解除する。 * テープを巻戻すか、カセットの向きを変えて入れ直す。
* 巻戻し中、テープが止まったり、再生したりする。	* メモリー機能かオートプレイ機能が動作している。	* メモリー機能の場合はリセット/CAL スイッチを押してメモリーを消す。オートプレイモードの場合はオートプレイスイッチを押して解除する。
* 録音できない。	* 誤消去防止用ツメがはずされている。 * 接続がおかしい。 * ヘッドが汚れている。	* 接着テープでツメの孔をおおう。 * 接続を確認する。 * ヘッドの清掃をする。
* 再生音がしない。	* 再生の時オートモニタースイッチがソース位置になっている。 * 出力レベル調整が最小になっている。	* オートモニタースイッチをテープ位置にする。 * 適当なレベルに調整する。
* 電源を入れると自動的に録音または再生してしまう。	* タイマースイッチがOFF 位置になっていない。	* タイマースイッチをOFF 位置にする。
* 録音時に信号がデッキに入力されない。	* 録音レベル調整が最小になっている。 * AL81とステレオの接続がおかしい。	* 適当なレベルに調整する。 * 接続やコードを確認する。
* 再生音に雑音がはいる 左右の音のバランスが悪い。	* ヘッドが汚れている。 * テープが張ったり、ゆるんだりする。	* ヘッドの清掃をする。 * テープを交換する。
* テープ・ヒスがひどい	* ヘッドが磁気を帯びている。 * テープの質が悪い。 * ヘッドが汚れている。 * ドルビースイッチのセットがおかしい。 * 録音レベルが低すぎる。	* ヘッドの消磁をする。 * テープを交換する。 * ヘッドの清掃をする。 * スイッチを正しい位置にセットする。 * 適当なレベルに調整する。
* 音が歪む。	* テープに録音されている音が歪んでいる。 * 録音レベルが高すぎる。	* 他のテープを聞いて確認する。 * 適当なレベルに調整する。
* ワウ/フラッターがひどく、音が中断される。	* ヘッド、ピンチローラー、キャプスタンが汚れている。 * テープの巻きが強すぎたり均一でなかったりする。	* ヘッドやテープの通る部分を清掃する。 * 早送りや巻戻しでテープを巻く。

症状	原因	処置
* 再生中ハム雑音が目立つ。	* コードが正しく接続されていない。 * アンプ電源トランス等の外部漏洩磁束が発生している。 * ヘッドが汚れている。	* コードを正しく接続する。 * デッキ周辺から蛍光灯、アンプ、トランス等の雑音発生源を遠ざける。 * ヘッドを清掃する。
* 高音が強すぎる。	* ドルビーNRシステムが正しく使われていない。	* 録音の時に設定したドルビーNRシステムを使う。
* 高音が弱い。	* ヘッドが汚れている。 * ドルビーNRシステムを設定しないで録音したテープをドルビーNRシステムを設定して再生している。	* ヘッドの清掃をする。 * ドルビーNRスイッチをOFFにする。
* タイマー録音をセットしてもタイマー再生しできない。	* 誤消去防止用ツメが取り除かれている。	* 接着テープをツメの穴に貼る。
* 校正調整不能	* 使い古したテープを使用している。 * ヘッドが汚れている。	* カセットテープを交換する。 * ヘッドの清掃をする。
* カウンターメモリー操作ができない。	* メモリースイッチがOFFになっている。	* メモリースイッチをONにする。

Voltage Chart

Notes: (1) Reference numbers marked "※" on the charts means as follows:

※ 1	Hat at PAC OUT
※ 2	L at High-speed FF or REW
※ 3	H at MEMORY mode on Time Counter (Prefered to ※ 2)
※ 4	10.4V at High-speed FF or REW
※ 5	11.2V at High-speed FF or REW
※ 6	10.0V at High-speed REW
※ 7	10.0V at High-speed FF
※ 8	9.0V at High-speed REW
※ 9	9.4V at High-speed FF
※10	9.6V at High speed FF
※11	8.0V at High-speed REW
※12	3.0V at High-speed FF or REW
※13	3.5V at High-speed FF or REW
※14	0.6V at High-speed FF or REW

(2) H (High) Level: 4.0V to 5.3V

L (Low) Level: 0V to 0.9V

(3) Mode unless otherwise specified: Power; ON, Function; STOP, PAC; OUT, Monitor; TAPE, Dolby NR; OFF, MPX Filter; OFF, Tape used; METAL

(4) Monitor Mode: TAPE at Playback, SOURCE at Recording with METAL tape use.

(5) Reference waveforms as follows:

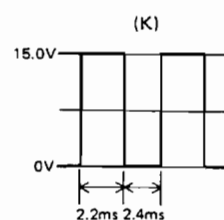
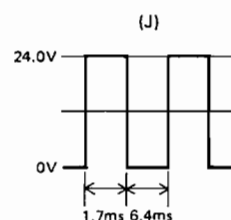
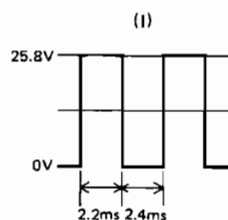
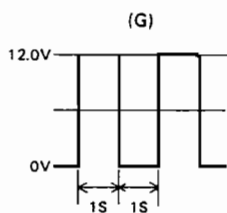
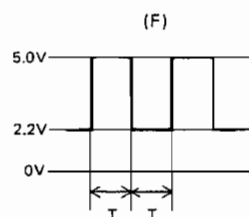
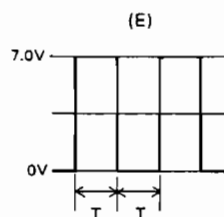
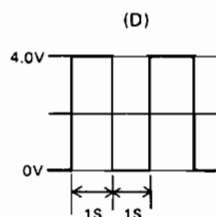
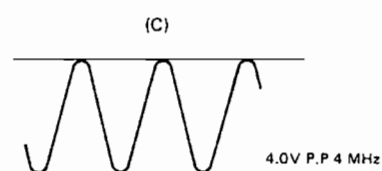
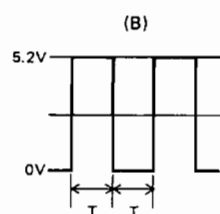
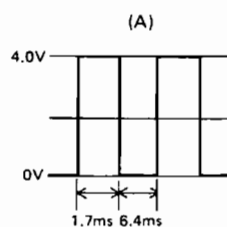

● Mother P.C. Board

Transistors (E: Emitter, C: Collector, B: Base)

Symbol	Mode	E	C	B
Q1001	—	14.6V	21.1V	15.9V
Q1003	—	-14.9V	-21.7V	-15.6V
Q1004	—	5.2V	11.6V	5.9V
Q1005	—	12.4V	18.0V	13.0V
Q1006	—	12.4V	18.0V	13.0V
Q1007	—	25.5V	37.0V	26.1V
Q2011	—	11.8V	14.7V	12.5V
Q2012	—	-11.4V	-14.8V	-12.4V
Q3001	—	0V	0V	0V
Q3002	—	0V	0V	0V
Q3003	—	0V	0V	0V
Q3004	—	0V	0V	0V
Q4001	—	0V	0V	0.7V
Q4002	—	0V	0V	0.7V
Q4003	—	0V	0V	0.7V
Q4004	—	0V	0V	0.7V
Q4009	—	0V	0V	0V
Q4010	—	0V	0V	0V
Q5001	P.B.	14.7V	0V	14.5V
	Rec	14.0V	13.4V	13.3V
Q5002	P.B.	0V	14.5V	0V
	Rec	0V	0V	0.6V
Q5003	P.B.	0V	0V	0V
	Rec	11.1V	13.4V	11.8V
Q5005	P.B.	0.3V	0V	0V
	Rec	3.8V	11.1V	3.2V
Q5006	P.B.	0.3V	0V	0V
	Rec	3.5V	11.1V	2.9V
Q5007	P.B.	0V	0V	-0.2V
	Rec	0V	5.3V	-0.2V
Q5008	P.B.	0V	0V	-0.1V
	Rec	0V	5.0V	-0.1V
Q5009	P.B.	0V	0V	-0.2V
	Rec	0V	5.3V	-0.2V
Q5010	P.B.	0V	0V	-0.1V
	Rec	0V	5.0V	-0.1V
Q5101	P.B.	0V	0V	0V
	Rec	0.6V	8.7V	1.3V
Q5102	P.B.	0V	0V	0V
	Rec	0.7V	8.6V	1.5V
Q5103	P.B.	0V	0.3V	0.3V
	Rec	0.1V	3.2V	0.4V
Q5104	P.B.	0V	0.3V	0.3V
	Rec	0.1V	2.8V	0.4V
Q5105	P.B.	0V	0.2V	0.2V
	Rec	0.1V	3.2V	0.5V
Q5106	P.B.	0V	0.3V	0.3V
	Rec	0.1V	2.9V	0.4V
Q5501	P.B.	0V	0V	0.6V
	Rec	0V	0V	-0.1V
Q5502	P.B.	0V	0V	0.6V
	Rec	0V	0V	-0.1V

FETs (S: Source, D: Drain, G: Gate)

Symbol	Mode	S1, 2	D1, 2	G1, 2
Q2001	—	0.4V	10.3V	0V
Q2002	—	0.4V	10.3V	0V
Symbol	Mode	S	D	G
Q2003	—	0V	0V	0.2V
Q2004	—	0V	0V	0.2V
Q2005	—	0V	0V	-13.4V
Q2006	—	0V	0V	-13.4V
Q5801	—	0V	0V	0V
Q5802	—	0V	0V	0V
Q5803	—	0V	0V	-13.5V
Q5804	—	0V	0V	-13.5V
Q5805	—	0V	0V	-13.5V
Q5806	—	0V	0V	-13.5V
Q5807	—	0V	0V	-13.5V
Q5808	—	0V	0V	-13.5V
Q4005	Tape	0V	0V	0V
	Source	0V	0V	-13.4V
Q4006	Tape	0V	0V	0V
	Source	0V	0V	-13.4V
Q4007	Tape	0V	0V	-13.4V
	Source	0V	0V	0V
Q4008	Tape	0V	0V	-13.4V
	Source	0V	0V	0V

ICs

Symbol Pin	IC3001	IC3002	IC3501	IC3502
1	7.7V	7.7V	7.7V	7.5V
2	0V	14.8V	0V	14.8V
3	14.8V	7.6V	7.7V	7.7V
4	10.6V	7.7V	10.6V	7.7V
5	10.5V	7.7V	10.5V	7.7V
6	0V	7.4V	0V	7.4V
7	0V	7.7V	0V	7.7V
8	0.2V	7.7V	0.2V	7.7V
9	0.2V	1.9V	0.2V	1.9V
10	7.7V	0.6V	7.7V	0.6V
11	0.2V	7.7V	0.2V	7.7V
12	0.2V	7.7V	0.2V	7.7V
13	7.7V	7.7V	7.7V	7.7V
14	7.7V	7.7V	7.7V	7.7V
15	7.7V	7.7V	7.7V	7.7V
16	7.7V	7.7V	7.7V	7.7V
17	7.7V	0.2V	7.7V	0.2V
18	7.7V	0.2V	7.7V	0.2V
19	0.6V	7.7V	0.6V	7.7V
20	1.9V	0.2V	1.9V	0.2V
21	7.7V	0.2V	7.7V	0.2V
22	7.7V	0V	7.7V	0V
23	7.4V	0V	7.4V	0V
24	7.7V	10.5V	7.7V	10.5V
25	7.7V	10.6V	7.7V	10.6V
26	7.6V	14.8V	7.7V	7.7V
27	14.8V	0V	14.8V	0V
28	7.7V	7.7V	7.5V	7.7V

Symbol Pin	IC2001	IC5501
1	0V	0V
2	10.3V	0V
3	10.3V	0V
4	-11.7V	-15.2V
5	10.3V	0V
6	10.3V	0V
7	0V	0V
8	11.8V	14.9V

● Test Tone P.C. Board

Transistors (E: Emitter, C: Collector, B: Base)

Symbol	Mode	E	C	B
Q2801	Off	0V	-15.0V	0V
	Level	6.6V	6.5V	5.9V
	Bias	5.7V	5.7V	5.0V
Q2802	Off	0V	0V	0.7V
	Level	0V	0V	0.7V
	Bias	0V	0V	0.7V
Q2803	Off	7.5V	15.0V	8.1V
	Level	7.5V	15.0V	8.1V
	Bias	7.5V	15.0V	8.1V
Q2804	Off	7.5V	15.0V	8.1V
	Level	7.5V	15.0V	8.1V
	Bias	7.5V	15.0V	8.1V
Q2805	Off	0V	0V	0V
	Level	0V	0V	0.7V
	Bias	0V	0V	0.7V
Q2806	Off	0V	0V	0V
	Level	0V	0V	0.7V
	Bias	0V	0V	0.7V
Q4501	-	0V	14.9V	0.6V
Q4502	-	0V	14.9V	0.6V
Q4503	-	0V	-15.2V	-0.6V
Q4504	-	0V	-15.2V	-0.6V
Q7001	-	1.9V	13.9V	2.4V
Q7002	-	1.9V	13.9V	2.4V
Q7003	-	0V	0V	-14.8V
Q7004	-	0V	0V	-14.8V
Q7005	-	0V	0V	-14.4V
Q7006	-	0V	0V	-14.4V
Q7204	Off	0V	0V	0.8V
	Level	0V	0V	-0.7V
	Bias	0V	0V	-0.8V
Q7205	Off	0V	0V	0.8V
	Level	0V	0V	-0.7V
	Bias	0V	0V	-0.8V
Q7801	-	0V	14.4V	0V
Q7802	-	6.9V	6.9V	7.5V
Q7803	-	0.1V	6.9V	0V
Q7804	-	0V	11.4V	0.1V

FETs (S: Source, D: Drain, G: Gate)

Symbol	Mode	S	D	G
Q7201	Off	0V	0V	-4.3V
	Level	0V	0V	-4.3V
	Bias	0V	0V	-0.2V
Q7202	Off	0V	0V	-1.9V
	Level	0V	0V	-1.6V
	Bias	0V	0V	0V
Q7203	Off	0V	0V	-1.5V
	Level	0V	0V	-1.5V
	Bias	0V	0V	-1.5V

ICs

Symbol Pin	IC4501	IC7001	IC7002	IC7003	IC7801
1	0V	0V	1.9V	2.4V	-11.4V
2	0V	0V	1.9V	1.9V	0.1V
3	0V	0V	1.9V	1.9V	0V
4	-15.2V	-15.2V	-15.2V	-15.2V	-12.8V
5	0V	0V	1.9V	1.9V	14.4V
6	0V	0V	1.9V	1.9V	5.0V
7	0V	0V	1.9V	2.4V	10.7V
8	14.9V	15.0V	15.0V	15.0V	11.4V

Symbol Mode	IC7201		
Pin	OFF	Level	Bias
1	0V	0V	0V
2	0V	0V	0V
3	0V	0V	0V
4	-15.2V	-15.2V	-15.2V
5	0V	0V	0V
6	0V	0V	0V
7	0V	0V	0V
8	15.0V	15.0V	15.0V

Symbol Pin	IC7802
1	11.4V
2	11.4V
3	0V
4	11.4V
5	0V
6	0V
7	0V
8	11.4V
9	11.4V
10	0V
11	11.4V
12	0V
13	0V
14	11.4V

● Control P.C. Board

Transistors (E: Emitter, C: Collector, B: Base)

Symbol No.	Mode	Stop	Pause	Play	FF	Rew	Rec/Play	Rec/Pause	Cue	Review	Auto Space
Q6001	E	4.8V	4.8V	4.4V	6.4V※4	6.4V※4	4.4V	4.8V	6.4V	6.4V	4.8V
	C	12.2V	12.2V	12.2V	12.2V	12.2V	12.2V	12.2V	12.2V	12.2V	12.2V
	B	5.2V	5.2V	5.2V	7.2V※5	7.2V※5	5.2V	5.2V	7.2V	7.2V	5.2V
Q6002	E	4.8V	4.8V	4.4V	6.4V※4	6.4V※4	4.4V	4.8V	6.4V	6.4V	4.8V
	C	4.8V	4.8V	0.8V	0.6V	6.0V※6	0.8V	4.8V	0.6V	6.0V	0.8V
	B	4.8V	4.8V	4.0V	6.0V※7	5.0V※8	4.0V	4.8V	6.0V	5.0V	4.0V
Q6003	E	4.8V	4.8V	4.4V	6.4V※4	6.4V※4	4.4V	4.8V	6.4V	6.4V	4.8V
	C	4.8V	4.8V	3.6V	5.8V※9	0.6V	3.6V	4.8V	5.8V	0.6V	3.6V
	B	4.8V	4.8V	3.0V	5.0V※10	6.0V※11	3.0V	4.8V	5.0V	6.0V	3.0V
Q6004	E	0V	0V	0V	0V	0V	0V	0V	0V	0V	0V
	C	4.8V	4.8V	0.8V	0.6V	6.0V※6	0.8V	4.8V	0.6V	6.0V	0.8V
	B	0V	0V	1.2V	1.2V	0V	1.2V	0V	1.2V	0V	1.2V
Q6005	E	0V	0V	0V	0V	0V	0V	0V	0V	0V	0V
	C	4.8V	4.8V	3.6V	5.8V※9	0.6V	3.6V	4.8V	5.8V	0.6V	3.6V
	B	0V	0V	0V	0V	1.2V	0V	0V	0V	1.2V	0V
Q6006	E	10.6V	10.6V	10.6V	10.6V	10.6V	10.6V	10.6V	10.6V	10.6V	10.6V
	C	12V	12V	12V	12V	12V	12V	12V	12V	12V	12V
	B	11V	11V	11V	11V	11V	11V	11V	11V	11V	11V
Q6007	E	10.6V	10.6V	10.6V	10.6V	10.6V	10.6V	10.6V	10.6V	10.6V	10.6V
	C	10.4V (0.6V at Head Base "Down")									
	B	10.4V (1.8V at Head Base "Up")									
Q6008	E	10.6V	10.6V	10.6V	10.6V	10.6V	10.6V	10.6V	10.6V	10.6V	10.6V
	C	10.4V (0.6V at Head Base "Up")									
	B	10.4V (1.8V at Head Base "Down")									
Q6009	E	0V	0V	0V	0V	0V	0V	0V	0V	0V	0V
	C	10.4V (0.6V at Head Base "Down")									
	B	0V (1.2V at Head Base "Down")									
Q6010	E	0V	0V	0V	0V	0V	0V	0V	0V	0V	0V
	C	10.4V (0.6V at Head Base "Up")									
	B	0V (1.2V at Head Base "Up")									
Q6011	E	24V	24V	24V	24V	24V	24V	24V	24V	24V	24V
	C	24V	24V	-15V	24V	24V	-15V	24V	-15V	-15V	-15V
	B	23V	23V	24V	23V	23V	24V	23V	24V	24V	24V
Q6012	E	24V	24V	24V	24V	24V	24V	24V	24V	24V	24V
	C	24V	24V	-15V	24V	24V	-15V	24V	24V	24V	-15V
	B	23V	23V	24V	23V	23V	24V	23V	23V	23V	24V
Q6013	E	24V	24V	24V	24V	24V	24V	24V	24V	24V	24V
	C	-15V	-15V	-15V	-15V	-15V	-15V	-15V	-15V	-15V	-15V
	B	24V	24V	24V	24V	24V	24V	24V	24V	24V	24V
Q6014	E	24V	24V	24V	24V	24V	24V	24V	24V	24V	24V
	C	24V	24V	24V	24V	24V	-15V	24V	24V	24V	24V
	B	23V	23V	23V	23V	23V	24V	23V	23V	23V	23V
Q6015	E	0V	0V	0V	0V	0V	0V	0V	0V	0V	0V
	C	0V	0V	24V	0V	0V	24V	0V	24V	24V	24V
	B	5.0V	5.0V	0V	5.0V	5.0V	0V	5.0V	0V	0V	0V
Q6016	E	0V	0V	0V	0V	0V	0V	0V	0V	0V	0V
	C	0V	0V	24V	0V	0V	24V	0V	0V	0V	24V
	B	5.0V	5.0V	0V	5.0V	5.0V	0V	5.0V	5.0V	5.0V	0V
Q6017	E	0V	0V	0V	0V	0V	0V	0V	0V	0V	0V
	C	24V	24V	24V	24V	24V	24V	24V	24V	24V	24V
	B	0V	0V	0V	0V	0V	0V	0V	0V	0V	0V
Q6018	E	0V	0V	0V	0V	0V	0V	0V	0V	0V	0V
	C	0V	0V	0V	0V	0V	24V	0V	0V	0V	0V
	B	5.0V	5.0V	5.0V	5.0V	5.0V	0V	5.0V	5.0V	5.0V	5.0V
Q6019	E	L	L	L	L	L	L	L	L	L	L
	C	1V at Base "L", 0V at Base "H".									
	B	L※3	L※3	L※3	H※2.3	H※2.3	L※3	L※3	H※3	H※3	L※3
Q6020	E	L	L	L	L	L	L	L	L	L	L
	C	5.0V at Base "L", 0V at Base "H"									
	B	H	H	H	L	L	H	H	L	L	H
Q6021	E	L	L	L	L	L	L	L	L	L	L
	C	12V (1V in Auto Play mode)									
	B	L (H in Auto Play mode)									

Symbol No.	Mode	Stop	Pause	Play	FF	Rew	Rec/Play	Rec/Pause	Cue	Review	Auto Space
Q6022	E	L	L	L	L	L	L	L	L	L	L
	C	12V (1V in Auto Rewind mode)									
	B	L (H in Auto Rewind mode)									
Q6023	E	L	L	L	L	L	L	L	L	L	L
	C	12V (1V in Memory mode)									
	B	L (H in Memory mode)									
Q6024	E	0V	0V	0V	0.6V※12	0V	0V	0V	0.6V	0V	0V
	C	L at IC6012's Pin No. 8 "H", H at same one "L".									
	B	0V	0V	0V	1.5V※13	0V	0V	0V	1.5V	0V	0V
Q6025	E	0V	0V	0V	0V	0.6 12	0V	0V	0V	0.6V	0V
	C	L at IC6012's Pin No. 8 "H", H at same one "L".									
	B	0V	0V	0V	0V	1.5V※13	0V	0V	0V	1.5V	0V
Q6026	E	0V	0V	0V	0V	0V	0V	0V	0V	0V	0V
	C	12V	12V	12V	11V※14	12V	12V	12V	11V	12V	12V
	B	0V	0V	0V	0.6V※12	0V	0V	0V	0.6V	0V	0V
Q6027	E	0V	0V	0V	0V	0V	0V	0V	0V	0V	0V
	C	12V	12V	12V	12V	11V※14	12V	12V	12V	11V	12V
	B	0V	0V	0V	0V	0.6V※12	0V	0V	0V	0.6V	0V
Q6028	E	0V	0V	0V	0V	0V	0V	0V	0V	0V	0V
	C	5.2V	5.2V	5.2V	7.2V※5	7.2V※5	5.2V	5.2V	7.2V	7.2V	5.2V
	B	-15V	-15V	-15V	-15V	-15V	-15V	-15V	-15V	-15V	-15V

IC's

Symbol Mode Pin	IC6001										
	Stop	Pause	Play	FF	Rew	Rec/Play	Rec/Pause	Cue	Review	Auto Space	
1	A	A	A	A	A	A	A	A	A	A	
11	H or L	H or L	B	B	B	B	H or L	B	B	B	
12	H or L	H or L	B	B	B	B	H or L	B	B	B	
13	L	L	L	L	L	L	L	L	L	L	
14	H	H	H	H	H	H	H	H	H	H	
18	L	L	L	L	L	L	L	L	L	L	
19	H	H	H	H	H	L	H	H	H	H	
21	L	L	H	H	L	H	L	H	L	H	
22	L	L	L	L	H	L	L	L	H	L	
23	H (H between music selections during Music Sensor operation)										
24	L (H at Head Base "Up")										
25	L (H at Head Base "Down")										
29	H	H	H	H	H	H	H	H	H	H	
30	C	C	C	C	C	C	C	C	C	C	
31	C	C	C	C	C	C	C	C	C	C	
32	L	L	L	L	L	L	L	L	L	L	
33	L	L	L	L	H	L	L	L	H	L	
34	L	L	L	H	L	L	L	H	L	L	
35	H	L	L	L	L	L	L	L	L	L	
36	L	L	L	L	L	L	L	L	L	D	
37	L	H	L	L	L	L	H	L	L	L	
38	L	D	H	L	L	H	D	D	D	H	
39	L	L	L	L	L	H	H	L	L	H	
48	L	L	L	L	L	L	L	L	L	L	
61	A	A	A	A	A	A	A	A	A	A	
62	A	A	A	A	A	A	A	A	A	A	
63	A	A	A	A	A	A	A	A	A	A	
64	H	H	H	H	H	H	H	H	H	H	
IC6002											
12	L	L	L	L	L	L	L	L	L	L	
21	H	H	H	H	H	H	H	H	H	H	
24	H	H	H	H	H	H	H	H	H	H	

Symbol	IC6003										
Mode Pin	Stop	Pause	Play	FF	Rew	Rec/Play	Rec/Pause	Cue	Review	Auto Space	
2	L	L	L	L	L	L	L	L	L	L	
4	L	L	L	L	L	L	L	L	L	L	
6	L	L	L	L	L	L	L	L	L	L	
8	L	L	L	L	L	L	L	L	L	L	
10	L	H	L	L	L	L	H	H	H	L	
12	L	L	L	L	L	L	L	L	L	L	
14	L	L	L	L	L	L	L	L	L	L	
16	H	H	H	H	H	H	H	H	H	H	
IC6004											
2	H (L in Timer Recording)										
4	H (L in Timer Play)										
6	L	L	L	L	L	L	L	L	L	L	
8	L	L	L	L	L	L	L	L	L	L	
10	H	H	H	H	H	H	H	H	H	H	
12	H	L	L	H	H	L	L	L	L	L	
14	L	L	H	H	H	H	L	L	L	H	
16	H	H	H	H	H	H	H	H	H	H	
IC6005											
1	H (L with Rec Key)										
2	H (L with Stop Key)										
3	H (L at WPS ON)										
4	L (※1)	L	L	L	L	L	L	L	L	L	
5	H	H	H	H	H	H	H	H	H	H	
12	L	L	L	L	L	L	L	L	L	L	
13	H (L with Auto Rew Key)										
14	H (L with Auto Play Key)										
15	H (L with Call Key)										
16	H (L with Memory Key)										
17	H (L with Reset Key)										
18	H (L with Time Key)										
19	H (L with Record Mute Key)										
20	H (L with Pause Key)										
21	H (L with FF Key)										
22	H (L with Play Key)										
23	H (L with Rew Key)										
24	H	H	H	H	H	H	H	H	H	H	
IC6006											
1	L	L	L	H (※2)	H (※2)	L	L	H	H	L	
2	H (L with Monitor Key)										
3	H	H	H	H	H	H	H	H	H	H	
4	H (L with Metal Switch ON)										
5	H (L with CrO ₂ Switch ON)										
12	L	L	L	L	L	L	L	L	L	L	
13	L (H with Music Sensor ON)										
14	H	H	L	H	H	L	H	H	H	L	
15	H	H	L	H	H	L	H	L	L	L	
16	L	L	L	L	L	L	L	L	L	L	
17	L (H with CrO ₂ Tape Loaded)										
18	L (H with Norm Tape Loaded)										
19	L	L	L	L	L	L	L	L	L	L	
20	L (H with Metal Tape Loaded)										
21	L (H during Source Monitoring)										
22	H (L during Tape Monitoring)										
23	H	H	H	L	L	H	H	L	L	H	
24	H	H	H	H	H	H	H	H	H	H	

Symbol		IC6007									
Pin	Mode	Stop	Pause	Play	FF	Rew	Rec/Play	Rec/Pause	Cue	Review	Auto Space
		1	L (H during Counter Time mode)								
2	L	L	L	L	L	L	L	L	L	L	L
3	L	L	L	L	L	L	L	L	L	L	L
4	L	L	L	L	L	L	L	L	L	L	L
5	L	L	L	L	L	L	L	L	L	L	L
12	L	L	L	L	L	L	L	L	L	L	L
21	L (H during Memory ON)										
22	L (H during Auto Rew mode)										
23	L (H during Auto Play mode)										
24	H	H	H	H	H	H	H	H	H	H	H
		IC6008									
1	-15V (15V at Pin No. 3 "H")										
2	1.5V	1.5V	1.5V	1.5V	1.5V	1.5V	1.5V	1.5V	1.5V	1.5V	1.5V
3	L (H with Norm Tape Loaded)										
4	15V	15V	15V	15V	15V	15V	15V	15V	15V	15V	15V
5	L (H with CrO ₂ Tape Loaded)										
6	1.5V	1.5V	1.5V	1.5V	1.5V	1.5V	1.5V	1.5V	1.5V	1.5V	1.5V
7	-15V (15V at Pin No. 5 "H")										
8	-15V (15V at Pin No. 10 "H")										
9	1.5V	1.5V	1.5V	1.5V	1.5V	1.5V	1.5V	1.5V	1.5V	1.5V	1.5V
10	L (H during Tape Monitoring)										
11	-15V	-15V	-15V	-15V	-15V	-15V	-15V	-15V	-15V	-15V	-15V
12	L (H during Source Monitoring)										
13	1.5V	1.5V	1.5V	1.5V	1.5V	1.5V	1.5V	1.5V	1.5V	1.5V	1.5V
14	-15V (15V at Pin No. 12 "H")										
		IC6009									
1	-15V (15V at Pin No. 3 "H")										
2	1.5V	1.5V	1.5V	1.5V	1.5V	1.5V	1.5V	1.5V	1.5V	1.5V	1.5V
3	L (H at Metal 50 SW ON with Metal Tape Loaded)										
4	-15V	-15V	-15V	-15V	-15V	-15V	-15V	-15V	-15V	-15V	-15V
5	L (H with Metal Tape Loaded)										
6	1.5V	1.5V	1.5V	1.5V	1.5V	1.5V	1.5V	1.5V	1.5V	1.5V	1.5V
7	L (15V at pin No. 5 "H")										
8	15V	15V	15V	15V	15V	15V	15V	15V	15V	15V	15V
		IC6010									
1	H or L	H or L	B	B	B	B	H or L	B	B	B	B
2	7.0V or 0V	7.0V or 0V	E	E	E	E	7.0V or 0V	E	E	E	E
3	5.0V or 2.2V	5.0V or 2.2V	F	F	F	F	5.0V or 2.2V	F	F	F	F
4	L	L	L	L	L	L	L	L	L	L	L
5	5.0V or 2.2V	5.0V or 2.2V	F	F	F	F	5.0V or 2.2V	F	F	F	F
6	7.0V or 0V	7.0V or 0V	E	E	E	E	7.0V or 0V	E	E	E	E
7	H or L	H or L	B	B	B	B	H or L	B	B	B	B
8	H	H	H	H	H	H	H	H	H	H	H
		IC6011									
1	0V	0V	0V	0V	0V	0V	0V	0V	0V	0V	0V
2	2.8V	2.8V	2.8V	2.8V	2.8V	2.8V	2.8V	2.8V	2.8V	2.8V	2.8V
3	2.4V	2.4V	2.4V	2.4V	2.4V	2.4V	2.4V	2.4V	2.4V	2.4V	2.4V
4	0V	0V	0V	0V	0V	0V	0V	0V	0V	0V	0V
5	2.5V	2.5V	2.5V	2.5V	2.5V	2.5V	2.5V	2.5V	2.5V	2.5V	2.5V
6	2.4V	2.4V	2.4V	2.4V	2.4V	2.4V	2.4V	2.4V	2.4V	2.4V	2.4V
7	5.0V	5.0V	5.0V	5.0V	5.0V	5.0V	5.0V	5.0V	5.0V	5.0V	5.0V
8	5.0V	5.0V	5.0V	5.0V	5.0V	5.0V	5.0V	5.0V	5.0V	5.0V	5.0V

Symbol		IC6012									
Mode	Pin	Stop	Pause	Play	FF	Rew	Rec/Play	Rec/Pause	Cue	Review	Auto Space
	3	L	L	L	L	L	L	L	L	L	L
	4	H	H	H	H	H	H	H	H	H	H
	5	L	L	L	L	L	L	L	L	L	L
	6	H	H	H	H	H	H	H	H	H	H
	7	L	L	L	L	L	L	L	L	L	L
	8	L at IC6012's Pin No. 9 "H", H at same one "L".									
	9	L*3	L*3	L*3	H*2.3	H*2.3	L*3	L*3	H	H	L*3
	10	H	H	H	H	H	H	H	H	H	H
	11	L	L	L	L	L	L	L	L	L	L
	12	H	H	H	H	H	H	H	H	H	H
	13	L	L	L	L	L	L	L	L	L	L
	14	H	H	H	H	H	H	H	H	H	H
Symbol		IC6013									
	1	L	L	L	L	H	L	L	L	H	L
	2	L	L	L	H	L	L	L	H	L	L
	3	H	L	L	L	L	L	L	L	L	L
	4	L	L	L	L	L	L	L	L	L	D
	5	L	H	L	L	L	L	H	L	L	L
	6	L	D	H	L	L	H	D	D	D	H
	7	L	L	L	L	L	H	H	L	L	H
	8	L	L	L	L	L	L	L	L	L	L
	9	L	L	L	L	L	L	L	L	L	L
	10	12V	12V	12V	12V	12V	0V	0V	12V	12V	0V
	11	12V	G	0V	12V	12V	0V	G	G	G	0V
	12	12V	0V	12V	12V	12V	12V	0V	12V	12V	12V
	13	12V	12V	12V	12V	12V	12V	12V	12V	12V	G
	14	0V	0V	0V	0V	0V	0V	0V	0V	0V	0V
	15	12V	12V	12V	0V	12V	12V	12V	0V	12V	12V
	16	12V	12V	12V	12V	0V	12V	12V	12V	0V	12V

● FL Meter P.C. Board

Transistors (E: Emitter, C: Collector, B: Base)

Symbol	E	C	B
Q7501	0V	12.5V	-0.2V
Q7502	0V	12.5V	-0.2V
Q7503	15.3V	26.0V	15.9V

IC's

Symbol No.	IC7501	IC7502	IC7503	IC7504	IC7505
1	0V	5.3V	0V	0V	0V
2	2.5V	0V	5.3V	0V	0V
3	15.3V	0V	0V	0V	0V
4	K	0V	0V	0V	0V
5	K	0V	0V	0V	K
6	0.1V	0V	0V	0V	K
7	0.1V	0V	0V	0V	K
8	0.1V	0V	0V	0V	K
9	0.1V	0V	0V	0V	0V
10	0.1V	25.8V	25.8V	25.8V	25.8V
11	0.1V	0V	0V	0V	I
12	0.1V	0V	0V	0V	I
13	0.1V	0V	0V	0V	I
14	0.1V	0V	0V	0V	I
15	0.1V	0V	0V	0V	0V
16	0.1V	0V	0V	0V	0V
17	0.1V	0V	25.1V	0V	0V
18	0.1V	25.1V	0V	0V	0V
19	0.1V				
20	0.1V				
21	0.1V				
22	0.1V				
23	0.1V				
24	0V				
25	15.3V				
26	2.4V				
27	1.9V				
28	1.9V				

● Counter P.C. Board

IC's

Symbol No.	IC7701	IC7702
1	0V	A
2	0V	0V
3	A	-
5	A	A
8	0V	0V
9	24.7V	24.7V
12	J	J
14	J	-
15	0V	0V
16	0V	J

Parts Layout on P.C. Boards

- Test Tone P.C. Board

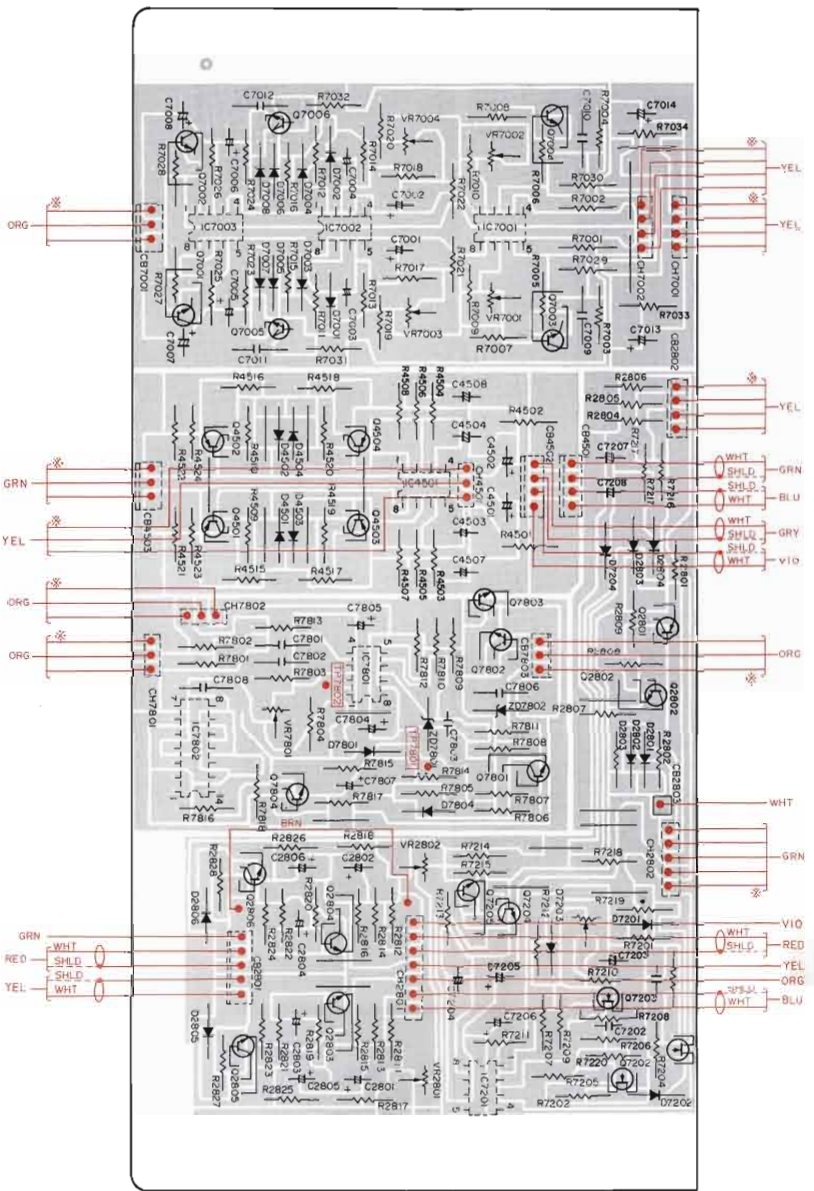

Bottom View

- Keyboard Switch P.C. Board

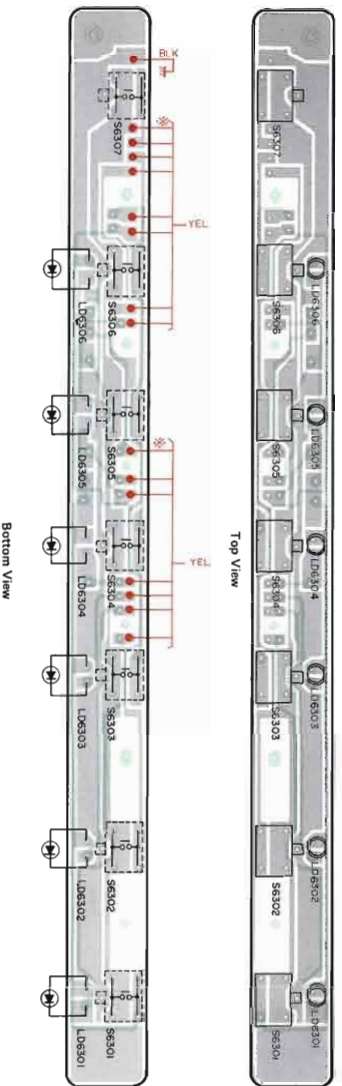

Top View

Bottom View

- FL Meter P.C. Board

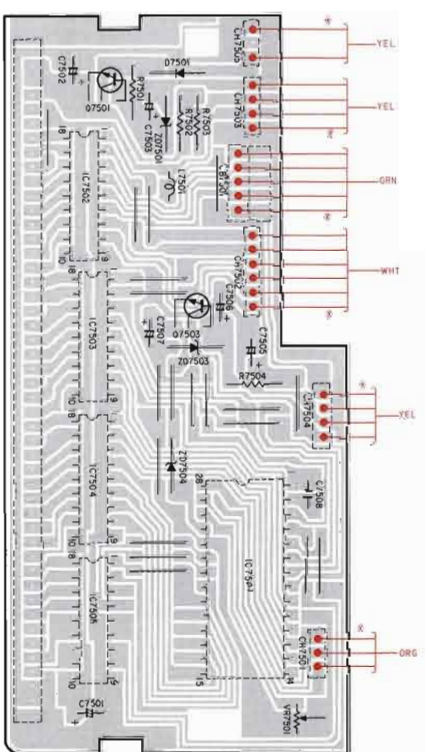

Bottom View

- Sensor P.C. Board

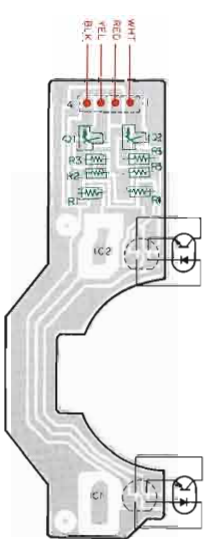

Bottom View

- Wire Assembly P.C. Board

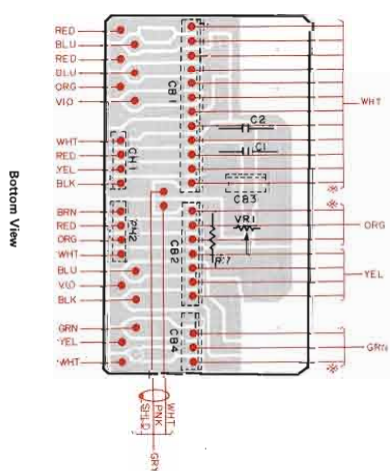

Bottom View

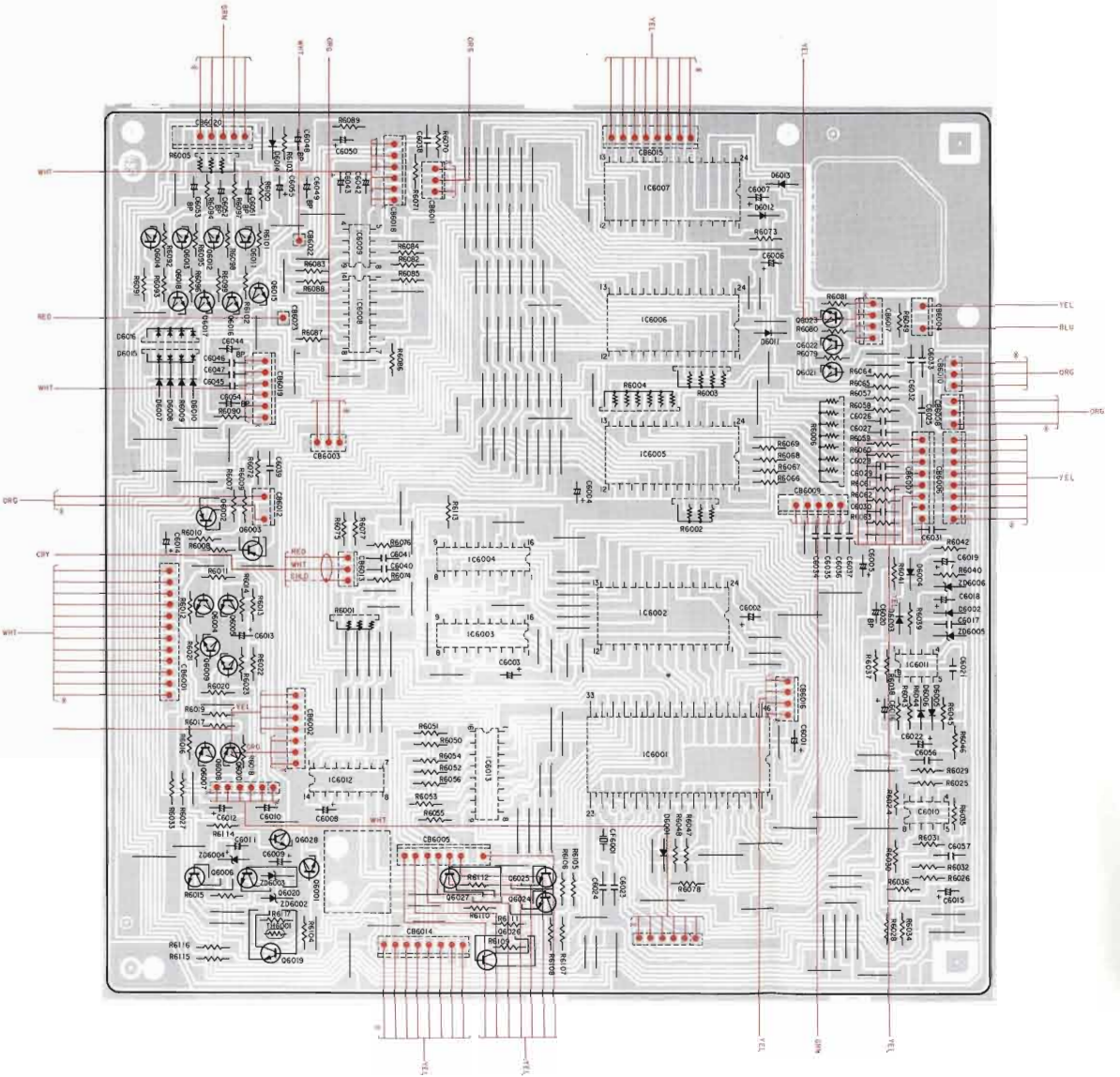

Bottom View

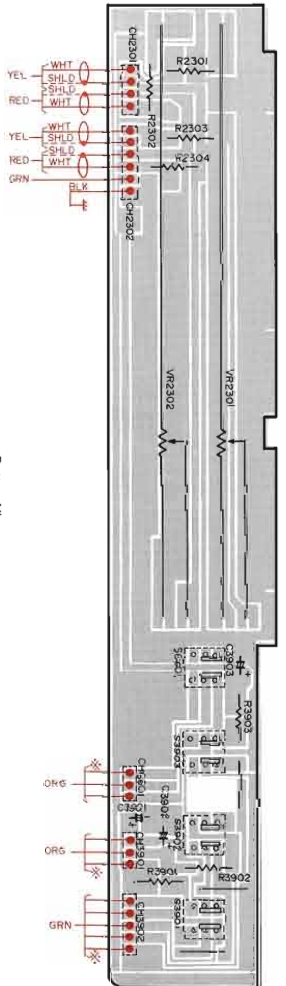

Bottom View

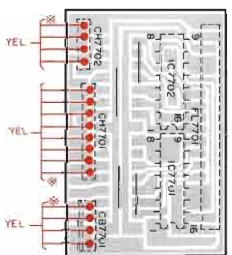

Bottom View

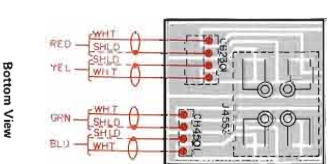

Bottom View

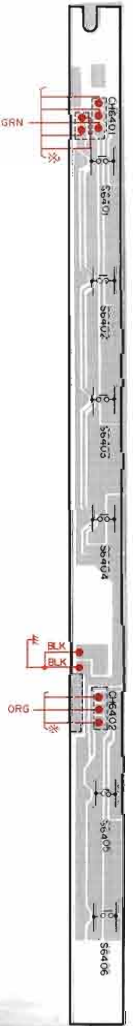

Bottom View

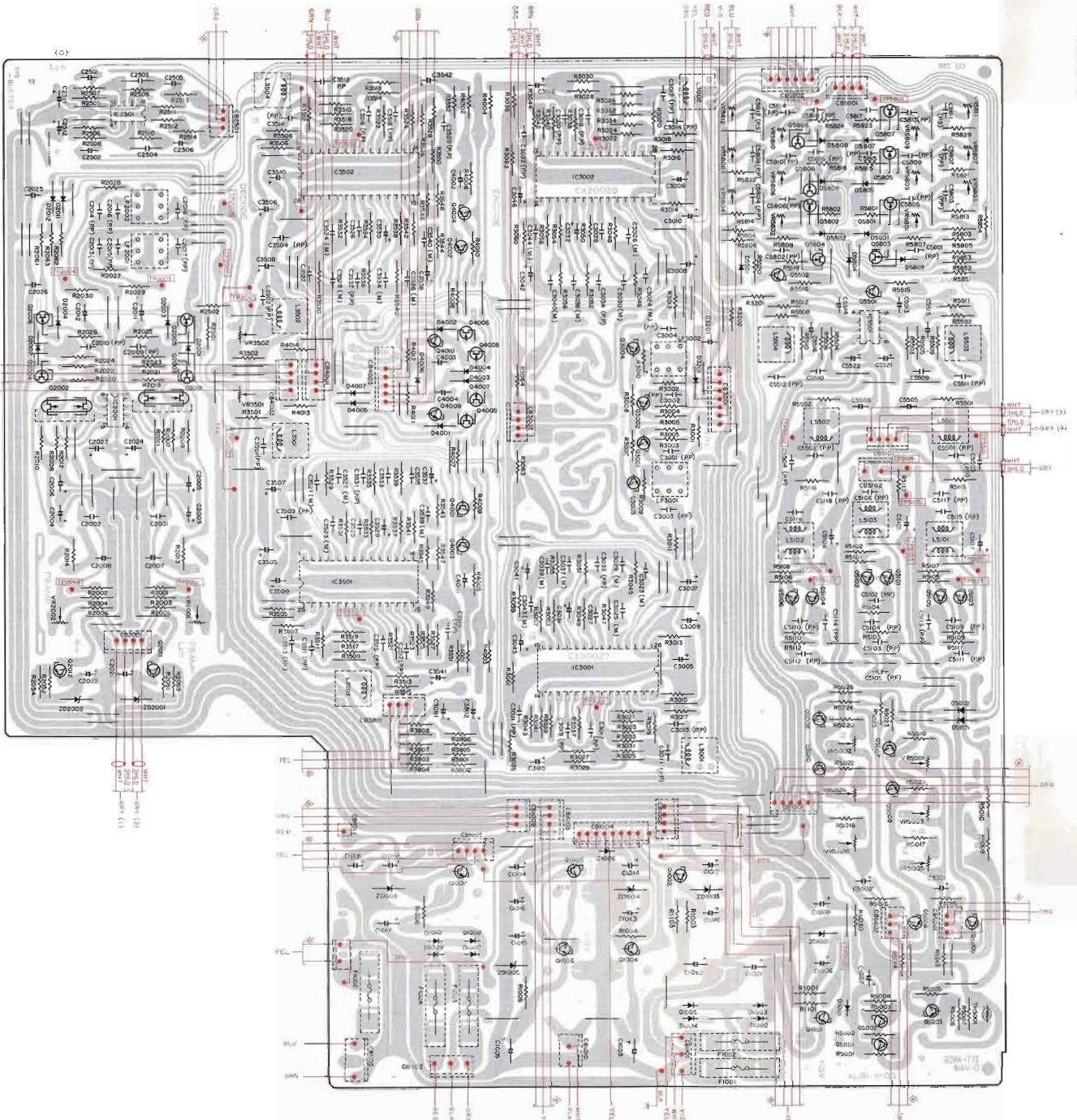

Bottom View

A B C D E F G H I J K L M N O P Q R S T U

• Head P.C. Board

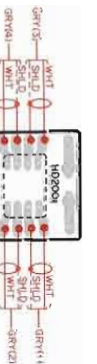

Bottom View

• Headphone P.C. Board

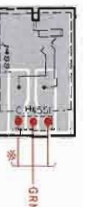

Bottom View

• LED P.C. Board



Bottom View

• Monitor Switch P.C. Board



Bottom View

• Remote DIN P.C. Board

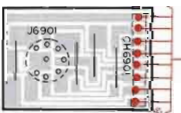

Bottom View

• Output Volume P.C. Board

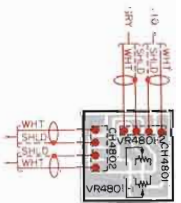

Bottom View

• Timer Switch P.C. Board



Bottom View

• Test Tone Switch P.C. Board

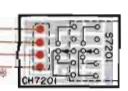

Bottom View

• Level Volume (L) P.C. Board

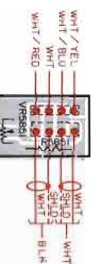

Bottom View

• Level Volume (R) P.C. Board

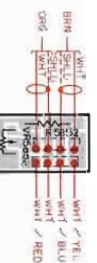

Bottom View

• Bias Volume (L) P.C. Board

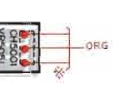

Bottom View

• Bias Volume (R) P.C. Board

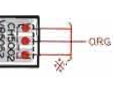

Bottom View

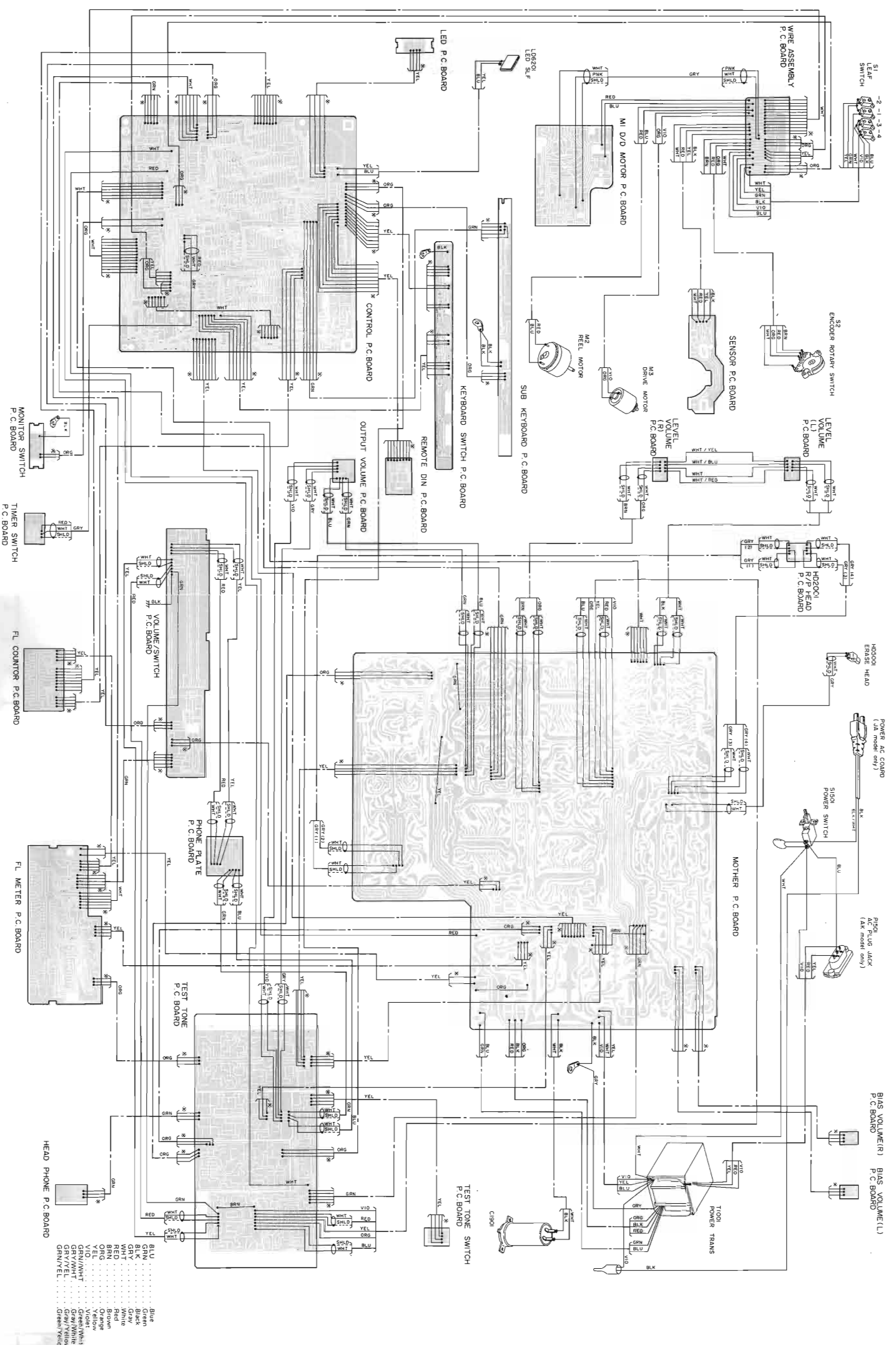

- Blue
- Green
- Black
- Red
- White
- Orange
- Yellow
- Violet
- Gray/White
- Gray/Yellow
- Green/Yellow

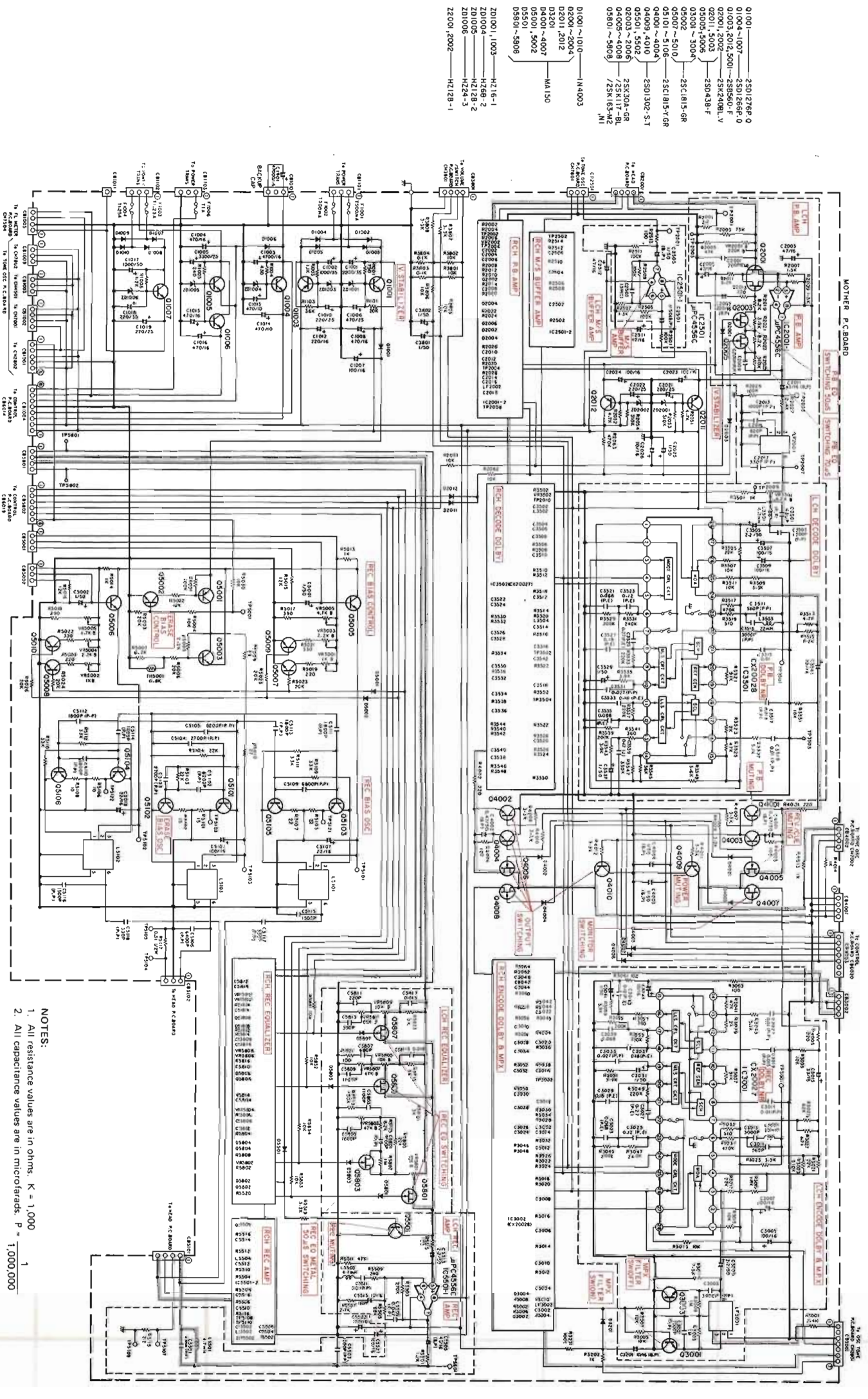

NOTES:

1. All resistance values are in ohms, K = 1,000
2. All capacitance values are in microfarads, P = 1/1,000,000

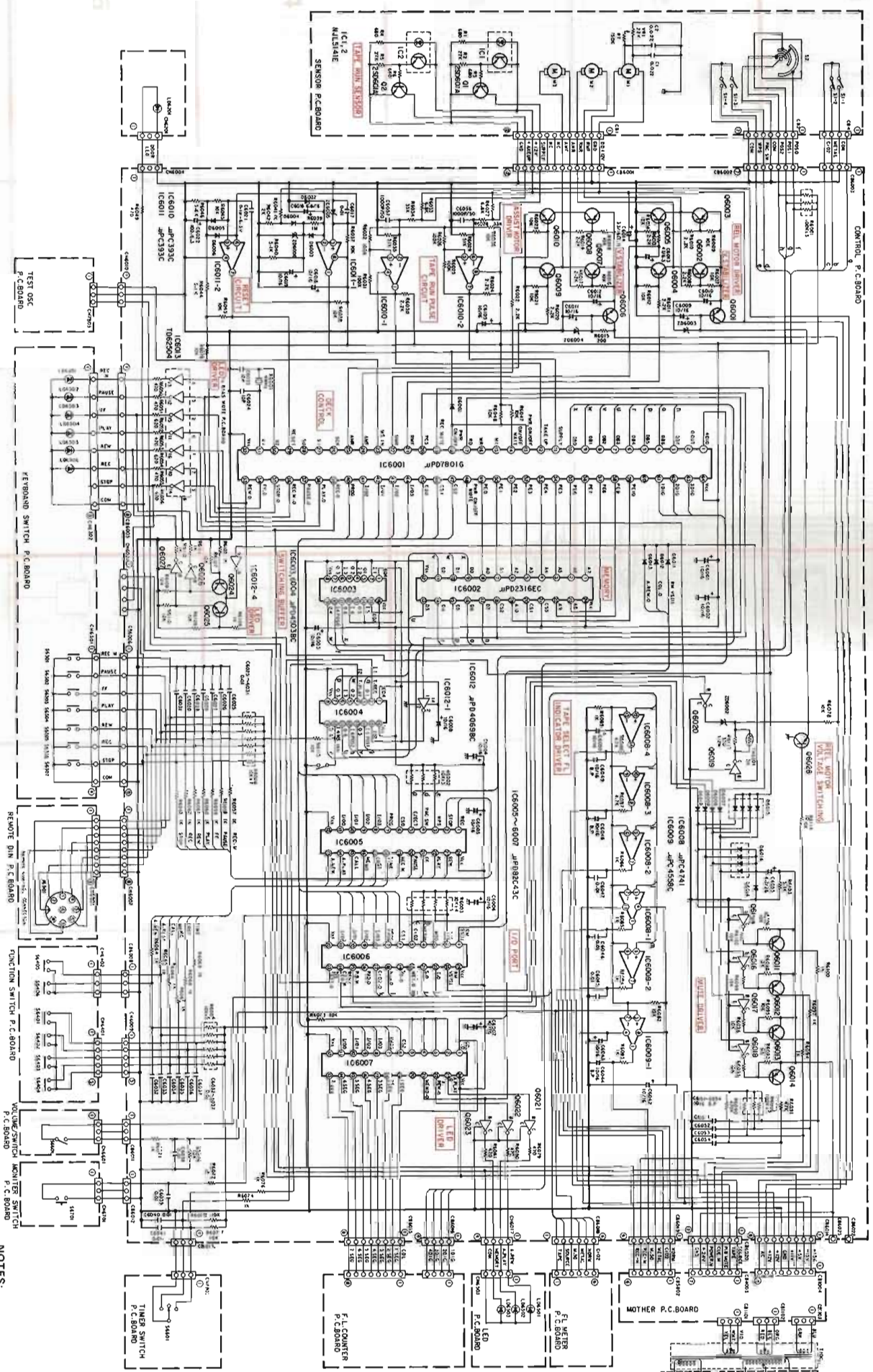

- NOTES:
1. All resistance values are in ohms. K = 1,000
 2. All capacitance values are in microfarads. P = 1,000,000

06901-6005	23012986 P-0
06904-6005	23013933
06903-6010	238977
06907-6008	238977
06907-6008	238977
06911-6014	238977
06915-6023	238977
06928-6027	23011023 T
06901-6014	MA165
06915-6016	MAF-401
206002-6006	NI2K-1
206003-6004	NI2K-1
206005-6004	NI2K-1
206005-6005	NI2K-1

Q2801	25A1733
Q2802	25A1705
Q2803, 2804	25C1172E
Q2804, 2805	25C1172E
Q4501, 4502	23C2123
Q4503, 4504	23A6173
Q7001 ~ 7006	23C2878
Q7201, 7202	25K1117
Q7203	25K163
Q7204	25K350A
Q7205	25K350B
Q7801 ~ 7803	25C1819
Q7901, 7903	25C1318
Q7902 ~ 7904	MA150
Q7905 ~ 7908	MA150
Q7909, 7904	HZ16-1
Q7910, 7904	HZ5C-1
Q7911	HZ5C-1
Q7912	HZ5C-1
Q7913	MA150
Q7914	HZ16-1
Q7915	HZ5C-1
Q7916	HZ5C-1
Q7917	HZ5C-1
Q7918	HZ5C-1
Q7919	HZ5C-1
Q7920	HZ5C-1
Q7921	HZ5C-1
Q7922	HZ5C-1
Q7923	HZ5C-1
Q7924	HZ5C-1
Q7925	HZ5C-1
Q7926	HZ5C-1
Q7927	HZ5C-1
Q7928	HZ5C-1
Q7929	HZ5C-1
Q7930	HZ5C-1
Q7931	HZ5C-1
Q7932	HZ5C-1
Q7933	HZ5C-1
Q7934	HZ5C-1
Q7935	HZ5C-1
Q7936	HZ5C-1
Q7937	HZ5C-1
Q7938	HZ5C-1
Q7939	HZ5C-1
Q7940	HZ5C-1
Q7941	HZ5C-1
Q7942	HZ5C-1
Q7943	HZ5C-1
Q7944	HZ5C-1
Q7945	HZ5C-1
Q7946	HZ5C-1
Q7947	HZ5C-1
Q7948	HZ5C-1
Q7949	HZ5C-1
Q7950	HZ5C-1
Q7951	HZ5C-1
Q7952	HZ5C-1
Q7953	HZ5C-1
Q7954	HZ5C-1
Q7955	HZ5C-1
Q7956	HZ5C-1
Q7957	HZ5C-1
Q7958	HZ5C-1
Q7959	HZ5C-1
Q7960	HZ5C-1
Q7961	HZ5C-1
Q7962	HZ5C-1
Q7963	HZ5C-1
Q7964	HZ5C-1
Q7965	HZ5C-1
Q7966	HZ5C-1
Q7967	HZ5C-1
Q7968	HZ5C-1
Q7969	HZ5C-1
Q7970	HZ5C-1
Q7971	HZ5C-1
Q7972	HZ5C-1
Q7973	HZ5C-1
Q7974	HZ5C-1
Q7975	HZ5C-1
Q7976	HZ5C-1
Q7977	HZ5C-1
Q7978	HZ5C-1
Q7979	HZ5C-1
Q7980	HZ5C-1
Q7981	HZ5C-1
Q7982	HZ5C-1
Q7983	HZ5C-1
Q7984	HZ5C-1
Q7985	HZ5C-1
Q7986	HZ5C-1
Q7987	HZ5C-1
Q7988	HZ5C-1
Q7989	HZ5C-1
Q7990	HZ5C-1
Q7991	HZ5C-1
Q7992	HZ5C-1
Q7993	HZ5C-1
Q7994	HZ5C-1
Q7995	HZ5C-1
Q7996	HZ5C-1
Q7997	HZ5C-1
Q7998	HZ5C-1
Q7999	HZ5C-1
Q8000	HZ5C-1

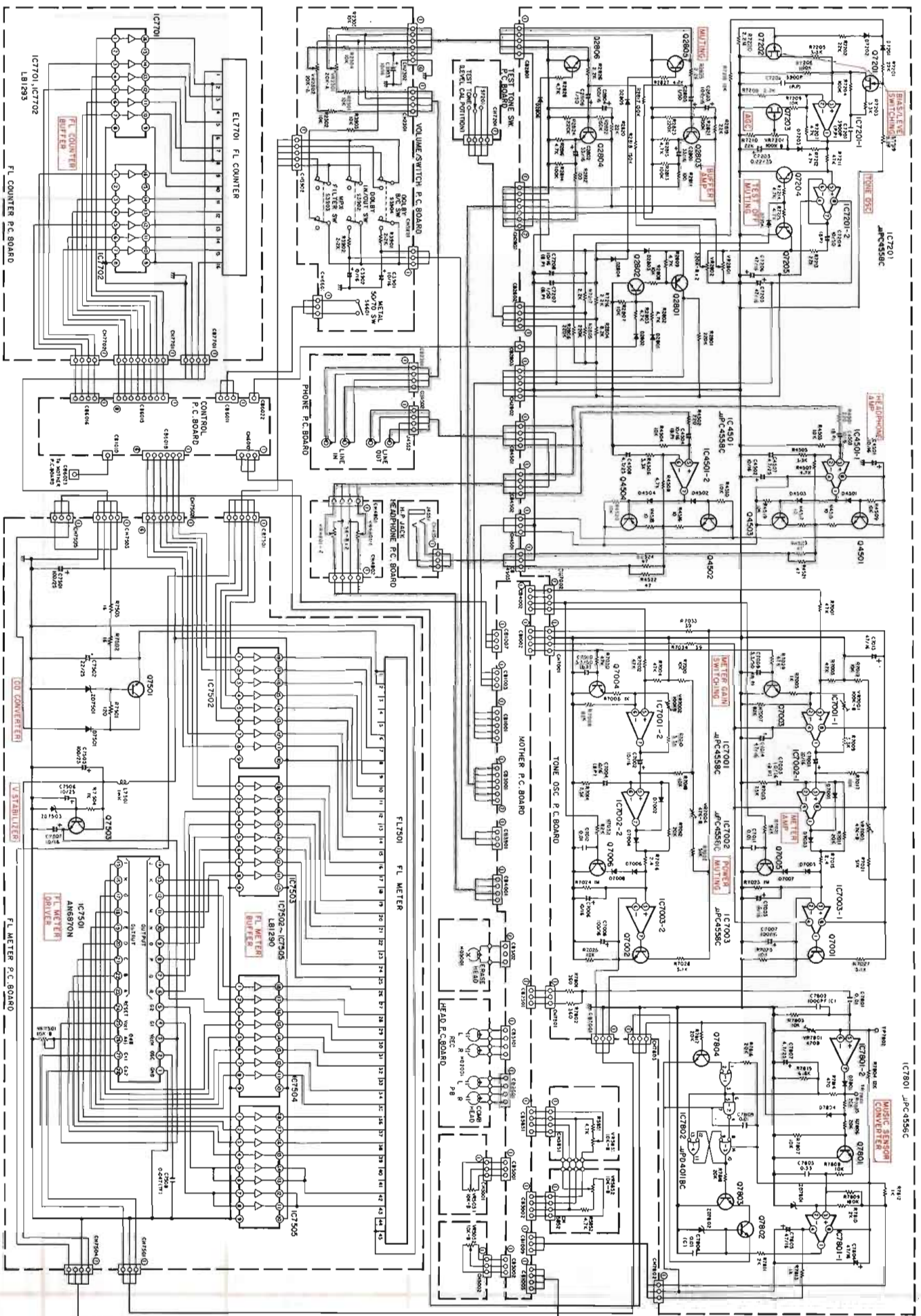

NOTES:
 1. All resistance values are in ohms. K = 1,000
 2. All capacitance values are in microfarads. P = 1,000,000

Electrical Parts List

Resistors (Carbon resistors that less than 1/4 watts are not entered on the parts list, please confirm them by schematic diagram.)
 uF = microfarads, pF = picofarads

Symbol No.	Part No.	Description
Sensor P.C. Board		
IC's		
IC1	51T60493F01	NJL5141
IC2	51T60493F01	NJL5141
Transistors		
Q1	48T52438F01	Chip, 2SD601A-RS/TX
Q2	48T52438F01	Chip, 2SD601A-RS/TX
Resistors		
R1	06S53330F49	Chip, 680 ohm 1/8W
R2	06S53330F87	Chip, 27K ohm 1/8W
R3	06S53330F49	Chip, 680 ohm 1/8W
R4	06S53330F49	Chip, 680 ohm 1/8W
R5	06S53330F87	Chip, 27K ohm 1/8W
R6	06S53330F49	Chip, 680 ohm 1/8W
Mother P.C. Board		
IC's		
IC2001	51T51173F01	μ PC4556C
IC2501	51T51173F01	μ PC4556C
IC3001	51T62563F01	CX20027
IC3002	51T62563F02	CX20028
IC3501	51T62563F02	CX20028
IC3502	51T62563F01	CX20027
IC5501	51T51173F01	μ PC4556C
Transistors		
Q1001	48T56029F01	2SD1276-P, Q
Q1003	48T58775F02	2SB560-F
Q1004	48T56031F01	2SD1266-P, Q
Q1005	48T56031F01	2SD1266-P, Q
Q1006	48T56031F01	2SD1266-P, Q

Symbol No.	Part No.	Description
Q1007	48T56031F01	2SD1266-P, Q
Q2001	48T60558F01	FET, 2SK240-BL
or	48T60558F02	FET, 2SK240-V
Q2002	48T60558F01	FET, 2SK240-BL
or	48T60558F02	FET, 2SK240-V
or	48T56375F03	FET, 2SK270A-BL
or	48T56375F04	FET, 2SK270A-V
Q2003	48T52152F01	FET, 2SK30A-GR
or	48S47729F02	FET, 2SK117BL
or	48T53397F06	FET, 2SK163-M2
or	48T53397F07	FET, 2SK163-N1
Q2004	48T52152F01	FET, 2SK30A-GR
or	48S47729F02	FET, 2SK117BL
or	48T53397F06	FET, 2SK163-M2
or	48T53397F07	FET, 2SK163-N1
Q2005	48T52152F01	FET, 2SK30A-GR
or	48S47729F02	FET, 2SK117BL
or	48T53397F06	FET, 2SK163-M2
or	48T53397F07	FET, 2SK163-N1
Q2006	48T52152F01	FET, 2SK30A-GR
or	48S47729F02	FET, 2SK117BL
or	48T53397F06	FET, 2SK163-M2
or	48T53397F07	FET, 2SK163-N1
Q2011	48T58776F02	2SD438-F
Q2012	48T58775F02	2SB560-F
Q3001	48S43525F03	2SC1815-GR
Q3002	48S43525F03	2SC1815-GR
Q3003	48S43525F03	2SC1815-GR
Q3004	48S43525F03	2SC1815-GR
Q4001	48T57305F01	2SD1302-S, T
Q4002	48T57305F01	2SD1302-S, T
Q4003	48T57305F01	2SD1302-S, T
Q4004	48T57305F01	2SD1302-S, T
Q4005	48T52152F01	FET, 2SK30A-GR
or	48S47729F02	FET, 2SK117BL
or	48T53397F06	FET, 2SK163-M2
or	48T53397F07	FET, 2SK163-N1
Q4006	48T52152F01	FET, 2SK30A-GR
or	48S47729F02	FET, 2SK117BL
or	48T53397F06	FET, 2SK163-M2
or	48T53397F07	FET, 2SK163-N1

Symbol No.	Part No.	Description
Q4007 or or or	48T52152F01 48S47729F02 48T53397F06 48T53397F07	FET, 2SK30A-GR FET, 2SK117BL FET, 2SK163-M2 FET, 2SK163-N1
Q4008 or or or	48T52152F01 48S47729F02 48T53397F06 48T53397F07	FET, 2SK30A-GR FET, 2SK117BL FET, 2SK163-M2 FET, 2SK163-N1
Q4009 Q4010 Q5001 Q5002	48T57305F01 48T57305F01 48T58775F02 48S43525F03	2SD1302-S, T 2SD1302-S, T 2SB560-F 2SC1815-GR
Q5003 Q5005 Q5006 or or Q5007 Q5008	48T58776F02 48T58776F02 48T58776F02 48T56375F03 48T56375F04 48S43525F03 48S43525F03	2SD438-F 2SD438-F 2SD438-F FET, 2SK270A-BL FET, 2SK270A-V 2SC1815-GR 2SC1815-GR
Q5009 Q5010 Q5101 Q5102 Q5103	48S43525F03 48S43525F03 48S43525F02 48S43525F02 48S43525F02	2SC1815-GR 2SC1815-GR 2SC1815-Y 2SC1815-Y 2SC1815-Y
Q5104 Q5105 Q5106 Q5501 Q5502	48S43525F02 48S43525F02 48S43525F02 48T57305F01 48T57305F01	2SC1815-Y 2SC1815-Y 2SC1815-Y 2SD1302-S, T 2SD1302-S, T
Q5801 or or or	48T52152F01 48S47729F02 48T53397F06 48T53397F07	FET, 2SK30A-GR FET, 2SK117BL FET, 2SK163-M2 FET, 2SK163-N1
Q5802 or or or	48T52152F01 48S47729F02 48T53397F06 48T53397F07	FET, 2SK30A-GR FET, 2SK117BL FET, 2SK163-M2 FET, 2SK163-N1
Q5803 or or or	48T52152F01 48S47729F02 48T53397F06 48T53397F07	FET, 2SK30A-GR FET, 2SK117BL FET, 2SK163-M2 FET, 2SK163-N1

Symbol No.	Part No.	Description
Q5804 or or or	48T52152F01 48S47729F02 48T53397F06 48T53397F07	FET, 2SK30A-GR FET, 2SK117BL FET, 2SK163-M2 FET, 2SK163-N1
Q5805 or or or	48T52152F01 48S47729F02 48T53397F06 48T53397F07	FET, 2SK30A-GR FET, 2SK117BL FET, 2SK163-M2 FET, 2SK163-N1
Q5806 or or or	48T52152F01 48S47729F02 48T53397F06 48T53397F07	FET, 2SK30A-GR FET, 2SK117BL FET, 2SK163-M2 FET, 2SK163-N1
Q5807 or or or	48T52152F01 48S47729F02 48T53397F06 48T53397F07	FET, 2SK30A-GR FET, 2SK117BL FET, 2SK163-M2 FET, 2SK163-N1
Q5808 or or or	48T52152F01 48S47729F02 48T53397F06 48T53397F07	FET, 2SK30A-GR FET, 2SK117BL FET, 2SK163-M2 FET, 2SK163-N1
Diodes		
D1001 D1002 D1003 D1004 D1005	48T61129F01 48T61129F01 48T61129F01 48T61129F01 48T61129F01	GP10 GP10 GP10 GP10 GP10
D1006 D1007 D1008 D1009 D1010	48T61129F01 48T61129F01 48T61129F01 48T61129F01 48T61129F01	GP10 GP10 GP10 GP10 GP10
D2001 or D2002 or D2003 or	48T51582F01 48T51881F01 48T51582F01 48T51881F01 48T51582F01 48T51881F01	MA-150 DS442-BT MA-150 DS442-BT MA-150 DS442-BT

Symbol No.	Part No.	Description
D2004 or D2011 or D2012 or	48T51582F01 48T51881F01 48T51582F01 48T51881F01 48T51582F01 48T51881F01	MA-150 DS442-BT MA-150 DS442-BT MA-150 DS442-BT
D3201 or D4001 or D4002 or	48T51582F01 48T51881F01 48T51582F01 48T51881F01 48T51582F01 48T51881F01	MA-150 DS442-BT MA-150 DS442-BT MA-150 DS442-BT
D4003 or D4004 or D4005 or	48T51582F01 48T51881F01 48T51582F01 48T51881F01 48T51582F01 48T51881F01	MA-150 DS442-BT MA-150 DS442-BT MA-150 DS442-BT
D4006 or D4007 or D5001 or	48T51582F01 48T51881F01 48T51582F01 48T51881F01 48T51582F01 48T51881F01	MA-150 DS442-BT MA-150 DS442-BT MA-150 DS442-BT
D5002 or D5501 or D5801 or	48T51582F01 48T51881F01 48T51582F01 48T51881F01 48T51582F01 48T51881F01	MA-150 DS442-BT MA-150 DS442-BT MA-150 DS442-BT
D5802 or D5803 or D5804 or	48T51582F01 48T51881F01 48T51582F01 48T51881F01 48T51582F01 48T51881F01	MA-150 DS442-BT MA-150 DS442-BT MA-150 DS442-BT
D5805 or D5806 or D5807 or	48T51582F01 48T51881F01 48T51582F01 48T51881F01 48T51582F01 48T51881F01	MA-150 DS442-BT MA-150 DS442-BT MA-150 DS442-BT

Symbol No.	Part No.	Description
D5808 or ZD1001 or ZD1003 or	48T51582F01 48T51881F01 48T52739F79 48T56372F60 48T52739F79 48T56372F60	MA-150 DS442-BT Zener, HZ16-1 Zener, RD16E-B2 Zener, HZ16-1 Zener, RD16E-B2
ZD1004 or ZD1005 or ZD1006 or	48T52739F38 48T56372F27 48T52739F74 48T56372F54 48T52739F93 48T56372F77	Zener, HZ6B-2 Zener, RD5.6E-B3 Zener, HZ12B-2 Zener, RD13E-B2 Zener, HZ24-3 Zener, RD27E-B1
ZD2001 or ZD2002 or	48T52739F73 48T56372F53 48T52739F73 48T56372F53	Zener, HZ12B-1 Zener, RD13E-B1 Zener, HZ12B-1 Zener, RD13E-B1
Thermistor		
TH5001	48T57369F16	Thermistor, 6.8K ohm
Inductors		
L3001 L3002 L3501 L3502 L3503	24T51914F07 24T51914F07 24T51914F01 24T51914F01 24T51914F07	Coil, Trap 22mH Coil, Trap 22mH Coil, Trap 4.7mH Coil, Trap 4.7mH Coil, Trap 22mH
L3504 L5101 L5102 L5103 L5501	24T51914F07 25T56004F01 25T56004F01 25T56004F01 24T51914F01	Coil, Trap 22mH Trans, OSC Trans, OSC Trans, OSC Coil, Trap 4.7mH
L5502 L5503 L5504	24T51914F01 24T51914F01 24T51914F01	Coil, Trap 4.7mH Coil, Trap 4.7mH Coil, Trap 4.7mH

Symbol No.	Part No.	Description
Fuses		
F1001	● 65T42077U13	Fuse, T-500mA
F1002	● 65T42077U13	Fuse, T-500mA
F1003	● 65T42077U17	Fuse, T-1.25A
F1004	● 65T42077U17	Fuse, T-1.25A
F1006	● 65T42077U16	Fuse, T-1A
Filters		
LF2001	91T64140F01	Filter, MPX (5303-156)
LF2002	91T64140F01	Filter, MPX (5303-156)
LF3001	91T64139F01	Filter, MPX (5303-157)
LF3002	91T64139F01	Filter, MPX (5303-157)
Resistors		
R5117	06C43205J01	Metal Film, 0.51 ohm 1/2W
VR2001	18T43406P01	Variable, 220K ohm-B 1/2W
VR2002	18T43406P01	Variable, 220K ohm-B 1/2W
VR3501	18B44064J02	Variable, 4.7K ohm 1/2W
VR3502	18B44064J02	Variable, 4.7K ohm 1/2W
VR5001	18B44064J09	Variable, 1.0K ohm 1/2W
VR5002	18B44064J09	Variable, 1.0K ohm 1/2W
VR5003	18B44064J08	Variable, 2.2K ohm 1/2W
VR5004	18B44064J08	Variable, 2.2K ohm 1/2W
VR5005	18B44064J02	Variable, 4.7K ohm 1/2W
VR5006	18B44064J02	Variable, 4.7K ohm 1/2W
VR5801	18T45040F13	Variable, 10K ohm 0.3W
VR5802	18T45040F13	Variable, 10K ohm 0.3W
VR5803	18T45040F17	Variable, 47K ohm 0.3W
VR5804	18T45040F17	Variable, 47K ohm 0.3W
VR5805	18T45040F13	Variable, 10K ohm 0.3W
VR5806	18T45040F13	Variable, 10K ohm 0.3W
VR5807	18T45040F17	Variable, 47K ohm 0.3W
VR5808	18T45040F17	Variable, 47K ohm 0.3W
VR5809	18T45040F13	Variable, 10K ohm 0.3W
VR5810	18T45040F13	Variable, 10K ohm 0.3W
VR5811	18T45040F18	Variable, 68K ohm 0.3W
VR5812	18T45040F18	Variable, 68K ohm 0.3W

Symbol No.	Part No.	Description
Capacitors		
C1001	23S41198U73	Electrolytic, 2200 uF/35V
C1002	23S41198U66	Electrolytic, 1000 uF/35V
C1003	23S41198U80	Electrolytic, 4700 uF/16V
C1004	23S41198U56	Electrolytic, 470 uF/16V
C1005	23S41198U77	Electrolytic, 3300 uF/25V
C1006	23S41198U57	Electrolytic, 470 uF/25V
C1007	23S40657F14	Electrolytic, 100 uF/16V
C1008	23S41198U56	Electrolytic,, 470 uF/16V
C1010	23S41198U42	Electrolytic, 220 uF/25V
C1012	23S40657F52	Electrolytic, 220 uF/16V
C1013	23S41198U55	Electrolytic, 470 uF/10V
C1014	23S41198U55	Electrolytic, 470 uF/10V
C1015	23S41198U56	Electrolytic, 470 uF/16V
C1016	23S41198U56	Electrolytic, 470 uF/16V
C1017	23S41198U67	Electrolytic, 1000 uF/50V
C1018	23S41198U43	Electrolytic, 220 uF/35V
C1019	23S41198U42	Electrolytic, 220 uF/25V
C2001	08T55119F41	Mica, 200 pF
C2002	08T55119F41	Mica, 200 pF
C2003	23T42478F08	Electrolytic, 47 uF/16V
C2004	23T42478F08	Electrolytic, 47 uF/16V
C2005	23T42478F08	Electrolytic, 47 uF/16V
C2006	23T42478F08	Electrolytic, 47 uF/16V
C2007	23T41366F21	Electrolytic (B.P), 220 uF/16V
C2008	23T41366F21	Electrolytic (B.P), 220 uF/16V
C2009	08T52448F32	Polystyrol, 6200 pF
C2010	08T52448F32	Polystyrol, 6200 pF
C2011	23T42477F38	Electrolytic (B.P), 33 uF/16V
C2012	23T42477F38	Electrolytic (B.P), 33 uF/16V
C2013	08T52448F13	Polystyrol, 1000 pF
C2014	08T52448F13	Polystyrol, 1000 pF
C2015	08T52448F11	Polystyrol, 820 pF
C2016	08T52448F11	Polystyrol, 820 pF
C2017	08T52448F01	Polystyrol, 330 pF
C2018	08T52448F01	Polystyrol, 330 pF
C2021	23S41198U42	Electrolytic, 220 uF/25V
C2022	23S41198U42	Electrolytic, 220 uF/25V
C2023	23S40657F14	Electrolytic, 100 uF/16V
C2024	23S40657F14	Electrolytic, 100 uF/16V
C2025	23T42477F16	Electrolytic (B.P), 1 uF/50V

Note: ● : AK model only, ■ : JA model only, Others: Common

Symbol No.	Part No.	Description
C2026	23T42477F06	Electrolytic (B.P), 10 uF/16V
C2501	23T42477F16	Electrolytic (B.P), 1 uF/50V
C2502	23T42477F16	Electrolytic (B.P), 1 uF/50V
C2503	08S44505P17	Ceramic, 15 pF
C2504	08S44505P17	Ceramic, 15 pF
C2505	23T42477F16	Electrolytic (B.P), 1 uF/50V
C2506	23T42477F16	Electrolytic (B.P), 1 uF/50V
C2511	23S40657F13	Electrolytic, 47 uF/16V
C2512	23S40657F13	Electrolytic, 47 uF/16V
C3001	08T52448F13	Polystyrol, 1000 pF
C3002	08T52448F13	Polystyrol, 1000 pF
C3003	08T52448F27	Polystyrol, 3900 pF
C3004	08T52448F27	Polystyrol, 3900 pF
C3005	23S40657F14	Electrolytic, 100 uF/16V
C3006	23S40657F14	Electrolytic, 100 uF/16V
C3007	23S40657F14	Electrolytic, 100 uF/16V
C3008	23S40657F14	Electrolytic, 100 uF/16V
C3009	23T42478F26	Electrolytic, 2.2 uF/50V
C3010	23T42478F26	Electrolytic, 2.2 uF/50V
C3011	08T52448F07	Polystyrol, 560 pF
C3012	08T52448F07	Polystyrol, 560 pF
C3013	08T52448F24	Polystyrol, 3000 pF
C3014	08T52448F24	Polystyrol, 3000 pF
C3015	23T42478F07	Electrolytic, 33 uF/16V
C3016	23T42478F07	Electrolytic, 33 uF/16V
C3017	08T52448F37	Polystyrol, 0.01 uF
C3018	08T52448F37	Polystyrol, 0.01 uF
C3019	08T52448F41	Polystyrol, 0.015 uF
C3020	08T52448F41	Polystyrol, 0.015 uF
C3021	08T52448F37	Polystyrol, 0.01 uF
C3022	08T52448F37	Polystyrol, 0.01 uF
C3023	08T57705F77	Mylar, 0.068 uF
C3024	08T57705F77	Mylar, 0.068 uF
C3025	08T57705F80	Mylar, 0.12 uF
C3026	08T57705F80	Mylar, 0.12 uF
C3027	08T57851F18	T.F., 0.27 uF
C3028	08T57851F18	T.F., 0.27 uF
C3029	08T57705F82	Mylar, 0.18 uF
C3030	08T57705F82	Mylar, 0.18 uF
C3031	23S40657F28	Electrolytic, 1 uF/50V
C3032	23S40657F28	Electrolytic, 1 uF/50V
C3033	08T52448F47	Polystyrol, 0.027 uF
C3034	08T52448F47	Polystyrol, 0.027 uF
C3037	08T57705F82	Mylar, 0.18 uF
C3038	08T57705F82	Mylar, 0.18 uF

Symbol No.	Part No.	Description
C3039	08T57705F77	Mylar, 0.068 uF
C3040	08T57705F77	Mylar, 0.068 uF
C3041	23S40657F28	Electrolytic, 1 uF/50V
C3042	23S40657F28	Electrolytic, 1 uF/50V
C3043	08T57705F80	Mylar, 0.12 uF
C3044	08T57705F80	Mylar, 0.12 uF
C3045	23T42478F05	Electrolytic, 10 uF/16V
C3046	23T42478F05	Electrolytic, 10 uF/16V
C3201	23T42477F06	Electrolytic (B.P), 10 uF/16V
C3501	08T52448F04	Polystyrol, 430 pF
C3502	08T52448F04	Polystyrol, 430 pF
C3503	08T52448F15	Polystyrol, 1200 pF
C3504	08T52448F15	Polystyrol, 1200 pF
C3505	23T42478F26	Electrolytic, 2.2 uF/50V
C3506	23T42478F26	Electrolytic, 2.2 uF/50V
C3507	23S40657F14	Electrolytic, 100 uF/16V
C3508	23S40657F14	Electrolytic, 100 uF/16V
C3509	23S40657F14	Electrolytic, 100 uF/16V
C3510	23S40657F14	Electrolytic, 100 uF/16V
C3511	08T52448F07	Polystyrol, 560 pF
C3512	08T52448F07	Polystyrol, 560 pF
C3513	08T52448F24	Polystyrol, 3000 pF
C3514	08T52448F24	Polystyrol, 3000 pF
C3515	08T52448F37	Polystyrol, 0.01 uF
C3516	08T52448F37	Polystyrol, 0.01 uF
C3517	08T52448F41	Polystyrol, 0.015 uF
C3518	08T52448F41	Polystyrol, 0.015 uF
C3519	08T52448F37	Polystyrol, 0.01 uF
C3520	08T52448F37	Polystyrol, 0.01 uF
C3521	08T57705F77	Mylar, 0.068 uF
C3522	08T57705F77	Mylar, 0.068 uF
C3523	08T57705F80	Mylar, 0.12 uF
C3524	08T57705F80	Mylar, 0.12 uF
C3525	08T57851F18	T.F., 0.27 uF
C3526	08T57851F18	T.F., 0.27 uF
C3527	08T57705F82	Mylar, 0.18 uF
C3528	08T57705F82	Mylar, 0.18 uF
C3529	23S40657F28	Electrolytic, 1 uF/50V
C3530	23S40657F28	Electrolytic, 1 uF/50V
C3531	08T52448F47	Polystyrol, 0.027 uF
C3532	08T52448F47	Polystyrol, 0.027 uF
C3533	08T57705F82	Mylar, 0.18 uF
C3534	08T57705F82	Mylar, 0.18 uF
C3535	08T57705F77	Mylar, 0.068 uF
C3536	08T57705F77	Mylar, 0.068 uF

Symbol No.	Part No.	Description
C3537	23S40657F28	Electrolytic, 1 uF/50V
C3538	23S40657F28	Electrolytic, 1 uF/50V
C3539	08T57705F80	Mylar, 0.12 uF
C3540	08T57705F80	Mylar, 0.12 uF
C3541	23T42478F07	Electrolytic, 33 uF/16V
C3542	23T42478F07	Electrolytic, 33 uF/16V
C3801	23S40657F28	Electrolytic, 1 uF/50V
C3802	23S40657F28	Electrolytic, 1 uF/50V
C4001	23T42477F15	Electrolytic (B.P), 0.47 uF/50V
C4002	23T42477F15	Electrolytic (B.P), 0.47 uF/50V
C4003	23T42477F16	Electrolytic (B.P), 1 uF/50V
C4004	23T42477F16	Electrolytic (B.P), 1 uF/50V
C5001	23S40657F28	Electrolytic, 1 uF/50V
C5002	23S40657F28	Electrolytic, 1 uF/50V
C5003	08T57705F80	Mylar 0.12 uF
C5101	23S40657F14	Electrolytic, 100 uF/16V
C5102	08T60792F04	Polystyrol, 8200 pF
C5103	08T60792F02	Polystyrol, 2700 pF
C5104	08T60792F02	Polystyrol, 2700 pF
C5105	08T60792F04	Polystyrol, 8200 pF
C5106	08T61630F68	Polystyrol, 6400 pF
C5107	23S40657F11	Electrolytic, 22 uF/16V
C5108	23S40657F11	Electrolytic, 22 uF/16V
C5109	08T52448F33	Polystyrol, 6800 pF
C5110	08T52448F33	Polystyrol, 6800 pF
C5111	08T52448F19	Polystyrol, 1800 pF
C5112	08T52448F19	Polystyrol, 1800 pF
C5113	08T52448F19	Polystyrol, 1800 pF
C5114	08T52448F19	Polystyrol, 1800 pF
C5115	08T52448F17	Polystyrol, 1500 pF
C5116	08T52448F17	Polystyrol, 1500 pF
C5117	08T52448F01	Polystyrol, 330 pF
C5118	08T52448F01	Polystyrol, 330 pF
C5501	08T52448F04	Polystyrol, 430 pF
C5502	08T52448F04	Polystyrol, 430 pF
C5503	08T52448F15	Polystyrol, 1200 pF
C5504	08T52448F15	Polystyrol, 1200 pF
C5505	23T42477F39	Electrolytic (B.P), 47 uF/16V
C5506	23T42477F39	Electrolytic (B.P), 47 uF/16V
C5509	08T57851F09	T.F., 0.047 uF
C5510	08T57851F09	T.F., 0.047 uF

Symbol No.	Part No.	Description
C5511	08T52448F37	Polystyrol, 0.01 uF
C5512	08T52448F37	Polystyrol, 0.01 uF
C5513	23T58711F31	Electrolytic (B.P), 2.2 uF/50V
C5514	23T58711F31	Electrolytic (B.P), 2.2 uF/50V
C5515	23T42477F06	Electrolytic (B.P), 10 uF/16V
C5516	23T42477F06	Electrolytic (B.P), 10 uF/16V
C5521	23S40657F14	Electrolytic, 100 uF/16V
C5522	23S40657F14	Electrolytic, 100 uF/16V
C5801	08T52448F36	Polystyrol, 9100 pF
C5802	08T52448F36	Polystyrol, 9100 pF
C5803	08T52448F14	Polystyrol, 1100 pF
C5804	08T52448F14	Polystyrol, 1100 pF
C5805	08T52448F18	Polystyrol, 1600 pF
C5806	08T52448F18	Polystyrol, 1600 pF
C5807	08T52448F09	Polystyrol, 680 pF
C5808	08T52448F09	Polystyrol, 680 pF
C5809	08T52448F14	Polystyrol, 1100 pF
C5810	08T52448F14	Polystyrol, 1100 pF
C5811	08T42081U09	Polystyrol, 220 pF
C5812	08T42081U09	Polystyrol, 220 pF
C5813	08T52448F01	Polystyrol, 330 pF
C5814	08T52448F01	Polystyrol, 330 pF
C5815	08T52448F43	Polystyrol, 0.018 uF
C5816	08T52448F43	Polystyrol, 0.018 uF
C5817	08T52448F41	Polystyrol, 0.015 uF
C5818	08T52448F41	Polystyrol, 0.015 uF
Control P.C. Board		
IC's		
IC6001	51T61508F01	μPD7801G
IC6002	51T62557F01	μPD2316EC
IC6003	51T62556F01	μPD4503BC
IC6004	51T62556F01	μPD4503BC
IC6005	51T62555F01	μPD82C43C
IC6006	51T62555F01	μPD82C43C
IC6007	51T62555F01	μPD82C43C
IC6008	51T53033F01	μPC4741C
IC6009	51S43471U02	μPC4558C
IC6010	51T62559F01	μPC393C

Symbol No.	Part No.	Description
IC6011	51T62559F01	μ PC393C
IC6012	51T50833F01	μ PD4069
IC6013	51T52158F01	TD62504
Transistors		
Q6001	48T56031F01	2SD1266-P, Q
Q6002	48T56032F01	2SB977A
Q6003	48T56032F01	2SB977A
Q6004	48T41365F02	2SD893-Q
or	48T41365F03	2SD893-R
or	48T41365F01	2SD893-P
Q6005	48T41365F02	2SD893-Q
or	48T41365F03	2SD893-R
or	48T41365F01	2SD893-P
Q6006	48T56031F01	2SD1266-P, Q
Q6007	48T56032F01	2SB977A
Q6008	48T56032F01	2SB977A
Q6009	48T41365F02	2SD893-Q
or	48T41365F03	2SD893-R
or	48T41365F01	2SD893-P
Q6010	48T41365F02	2SD893-Q
or	48T41365F03	2SD893-R
or	48T41365F01	2SD893-P
Q6011	48T56032F01	2SB977A
Q6012	48T56032F01	2SB977A
Q6013	48T56032F01	2SB977A
Q6014	48T56032F01	2SB977A
Q6015	48T62963F02	DTC-114
Q6016	48T62963F02	DTC-114
Q6017	48T62963F02	DTC-114
Q6018	48T62963F02	DTC-114
Q6019	48T62963F02	DTC-114
Q6020	48T62963F02	DTC-114
Q6021	48T62963F02	DTC-114
Q6022	48T62963F02	DTC-114
Q6023	48T62963F02	DTC-114
Q6024	48S43525F05	2SC1815-Y, GR
Q6025	48S43525F05	2SC1815-Y, GR
Q6026	48T62963F02	DTC-114
Q6027	48T62963F02	DTC-114
Q6028	48T57305F01	2SD1302-S, T

Symbol No.	Part No.	Description
Diodes		
D6001	48T44813F01	MA165TA
or	48T58583F01	1SS176
D6002	48T44813F01	MA165TA
or	48T58583F01	1SS176
D6003	48T44813F01	MA165TA
or	48T58583F01	1SS176
D6004	48T44813F01	MA165TA
or	48T58583F01	1SS176
D6005	48T44813F01	MA165TA
or	48T58583F01	1SS176
D6006	48T44813F01	MA165TA
or	48T58583F01	1SS176
D6007	48T44813F01	MA165TA
or	48T58583F01	1SS176
D6008	48T44813F01	MA165TA
or	48T58583F01	1SS176
D6009	48T44813F01	MA165TA
or	48T58583F01	1SS176
D6010	48T44813F01	MA165TA
or	48T58583F01	1SS176
D6011	48T44813F01	MA165TA
or	48T58583F01	1SS176
D6012	48T44813F01	MA165TA
or	48T58583F01	1SS176
D6013	48T44813F01	MA165TA
or	48T58583F01	1SS176
D6014	48T44813F01	MA165TA
or	48T58583F01	1SS176
D6015	51T62554F01	Array, DAP-401
D6016	51T62554F01	Array, DAP-401
ZD6002	48T40150U25	Zener, HZ5C-1
or	48T40732F18	Zener, RD5.1E-B2
ZD6003	48T40150U58	Zener, HZ11C-1
or	48T40732F43	Zener RD11E-B3
ZD6004	48T40150U58	Zener, HZ11C-1
or	48T40732F43	Zener, RD11E-B3
ZD6005	48T40150U08	Zener, HZ3C-2
or	48T40732F05	Zener, RD3.3EB1
ZD6006	48T40150U25	Zener, HZ5C-1
or	48T40732F18	Zener, RD5.1E-B2
Thermister		
TH6001	48T57369F14	Thermistor, 3K ohm

Symbol No.	Part No.	Description	
Crystal			
X6001	48T62936F01	Crystal, 4.0 MHz	
Resistors			
R6001	51T52333F09	Array,	100K ohm x 3
R6002	51T52333F08	Array,	10K ohm x 3
R6003	51T52333F02	Array,	10K ohm x 4
R6004	51T52333F03	Array,	10K ohm x 6
R6005	51T52333F09	Array,	100K ohm x 3
R6006	51T52333F04	Array,	10K ohm x 7
R6104	06C43205J12	Metal Film,	220 ohm 1/2W
R6117	06D44744G26	Carbon Film,	330 ohm 1/2W
Capacitors			
C6001	23S40657F10	Electrolytic,	10 uF/16V
C6002	23S40657F10	Electrolytic,	10 uF/16V
C6003	23S40657F10	Electrolytic,	10 uF/16V
C6004	23S40657F10	Electrolytic,	10 uF/16V
C6005	23S40657F10	Electrolytic,	10 uF/16V
C6006	23S40657F10	Electrolytic,	10 uF/16V
C6007	23S40657F10	Electrolytic,	10 uF/16V
C6008	23S40657F10	Electrolytic,	10 uF/16V
C6009	23S40657F10	Electrolytic,	10 uF/16V
C6010	23S40657F10	Electrolytic,	10 uF/16V
C6011	23S40657F10	Electrolytic,	10 uF/16V
C6012	23S40657F10	Electrolytic,	10 uF/16V
C6013	23S41059P34	Tantalum,	47 uF/6.3V
C6014	23S41059P38	Tantalum,	33 uF/16V
C6015	23S40657F10	Electrolytic,	10 uF/16V
C6016	23S40657F10	Electrolytic,	10 uF/16V
C6017	08T55260F61	Ceramic,	0.01 uF
C6018	23S41059P22	Tantalum,	6.8 uF/16V
C6019	23S40657F10	Electrolytic,	10 uF/16V
C6021	08T57705F79	Mylar,	0.1 uF
C6022	23S40657F03	Electrolytic,	100 uF/6.3V
C6023	08T55260F13	Ceramic,	10 pF
C6024	08T55260F13	Ceramic,	10 pF
C6025	08T55260F61	Ceramic,	0.01 uF
C6026	08T55260F61	Ceramic,	0.01 uF

Symbol No.	Part No.	Description	
C6027	08T55260F61	Ceramic,	0.01 uF
C6028	08T55260F61	Ceramic,	0.01 uF
C6029	08T55260F61	Ceramic,	0.01 uF
C6030	08T55260F61	Ceramic,	0.01 uF
C6031	08T55260F61	Ceramic,	0.01 uF
C6032	08T55260F61	Ceramic,	0.01 uF
C6033	08T55260F61	Ceramic,	0.01 uF
C6034	08T55260F61	Ceramic,	0.01 uF
C6035	08T55260F61	Ceramic,	0.01 uF
C6036	08T55260F61	Ceramic,	0.01 uF
C6037	08T55260F61	Ceramic,	0.01 uF
C6038	08T55260F61	Ceramic,	0.01 uF
C6039	08T55260F61	Ceramic,	0.01 uF
C6040	08T55260F61	Ceramic,	0.01 uF
C6041	08T55260F61	Ceramic,	0.01 uF
C6042	23S40657F10	Electrolytic,	10 uF/16V
C6043	23S40657F10	Electrolytic,	10 uF/16V
C6044	23T42477F06	Electrolytic (B.P),	10 uF/16V
C6045	08T55260F61	Ceramic,	0.01 uF
C6046	08T55260F61	Ceramic,	0.01 uF
C6047	08T55260F61	Ceramic,	0.01 uF
C6048	23T42477F06	Electrolytic (B.P),	10 uF/16V
C6049	23T42477F06	Electrolytic (B.P),	10 uF/16V
C6050	23S40657F10	Electrolytic,	10 uF/16V
C6051	23T42477F52	Electrolytic (B.P),	0.22 uF/50V
C6052	23T42477F52	Electrolytic (B.P),	0.22 uF/50V
C6053	23T42477F06	Electrolytic (B.P),	10 uF/16V
C6054	23T42477F06	Electrolytic (B.P),	10 uF/16V
C6055	23S40657F16	Electrolytic,	4.7 uF/25V
C6056	21C45322G28	Ceramic,	1000 pF
C6057	08T55260F49	Ceramic,	1000 pF
Tone O.S.C. P.C. Board			
IC's			
IC4501	51S43471U02	μPC4558C	
IC7001	51S43471U02	μPC4558C	
IC7002	51S43471U02	μPC4558C	
IC7003	51S43471U02	μPC4558C	
IC7201	51S43471U02	μPC4558C	
IC7801	51T51173F01	μPC4556C	
IC7802	51T66218F01	μPD4011BC	

Symbol No.	Part No.	Description
Transistors		
Q2801 or Q2802 Q2803 Q2804	48T40081T03 48T51118F01 48S43525F05 48T51175F01 48T51175F01	2SA733-(P) 2SA1015-Y 2SC1815-Y, GR 2SC1775E 2SC1775E
Q2805 Q2806 Q4501 Q4502 Q4503	48T57305F01 48T57305F01 48S42172J04 48S42172J04 48T40338U02	2SD1302-S, T 2SD1302-S, T 2SC1213-D 2SC1213-D 2SA673-D
Q4504 Q7001 Q7002 Q7003 Q7004	48T40338U02 48T51878F01 48T51878F01 48T51878F01 48T51878F01	2SA673-D 2SC2878-A, B 2SC2878-A, B 2SC2878-A, B 2SC2878-A, B
Q7005 Q7006 Q7201 or Q7202 or	48T51878F01 48T51878F01 48S47729F02 48T53397F06 48S47729F02 48T53397F06	2SC2878-A, B 2SC2878-A, B FET, 2SK117-BL FET, 2SK163-M2 FET, 2SK117-BL FET, 2SK163-M2
Q7203 Q7204 Q7205 Q7801 Q7802	48T52152F01 48T51878F01 48T51878F01 48S43525F03 48S43525F03	FET, 2SK30A-GR 2SC2878-A, B 2SC2878-A, B 2SC1815-GR 2SC1815-GR
Q7803 Q7804	48S43525F03 48S43525F03	2SC1815-GR 2SC1815-GR
Diodes		
D2801 or D2802 or D2803 or	48T51582F01 48T51881F01 48T51582F01 48T51881F01 48T51582F01 48T51881F01	MA-150 DS442-BT MA-150 DS442-BT MA-150 DS442-BT
D2804 or D2805 or D2806 or	48T51582F01 48T51881F01 48T51582F01 48T51881F01 48T51582F01 48T51881F01	MA-150 DS442-BT MA-150 DS442-BT MA-150 DS442-BT

Symbol No.	Part No.	Description
D4501 or D4502 or D4503 or	48T51582F01 48T51881F01 48T51582F01 48T51881F01 48T51582F01 48T51881F01	MA-150 DS442-BT MA-150 DS442-BT MA-150 DS442-BT
D4504 or D7001 or D7002 or	48T51582F01 48T51881F01 48T51582F01 48T51881F01 48T51582F01 48T51881F01	MA-150 DS442-BT MA-150 DS442-BT MA-150 DS442-BT
D7003 or D7004 or D7005 or	48T51582F01 48T51881F01 48T51582F01 48T51881F01 48T51582F01 48T51881F01	MA-150 DS442-BT MA-150 DS442-BT MA-150 DS442-BT
D7006 or D7007 or D7008 or	48T51582F01 48T51881F01 48T51582F01 48T51881F01 48T51582F01 48T51881F01	MA-150 DS442-BT MA-150 DS442-BT MA-150 DS442-BT
D7201 or D7202 or D7203 or	48T51582F01 48T51881F01 48T51582F01 48T51881F01 48T51582F01 48T51881F01	MA-150 DS442-BT MA-150 DS442-BT MA-150 DS442-BT
D7204 or D7801 or D7802 or	48T51582F01 48T51881F01 48T51582F01 48T51881F01 48T51582F01 48T51881F01	MA-150 DS442-BT MA-150 DS442-BT MA-150 DS442-BT
ZD7801 ZD7802	48T52739F31 48T52739F31	Zener, HZ5C-1 Zener, HZ5C-1
Resistors		
VR2801 VR2802 VR7001 VR7002 VR7003	18C41732G06 18C41732G06 18C41732G04 18C41732G04 18C41732G09	Variable, 10K ohm-B Variable, 10K ohm-B Variable, 100K ohm Variable, 100K ohm Variable, 47K ohm

Symbol No.	Part No.	Description
VR7004	18C41732G09	Variable, 47K ohm
VR7201	18C41732G04	Variable, 100K ohm
VR7801	18C41732G10	Variable, 470 ohm
Capacitors		
C2801	23S40657F12	Electrolytic, 33 uF/16V
C2802	23S40657F12	Electrolytic, 33 uF/16V
C2803	23S40657F14	Electrolytic, 100 uF/16V
C2804	23S40657F14	Electrolytic, 100 uF/16V
C2805	23S40657F28	Electrolytic, 1 uF/50V
C2806	23S40657F28	Electrolytic, 1 uF/50V
C4501	23S40657F10	Electrolytic, 10 uF/16V
C4502	23S40657F10	Electrolytic, 10 uF/16V
C4503	23T42477F06	Electrolytic (B.P), 10 uF/16V
C4504	23T42477F06	Electrolytic (B.P), 10 uF/16V
C4507	23T42477F09	Electrolytic (B.P), 4.7 uF/25V
C4508	23T42477F09	Electrolytic (B.P), 4.7 uF/25V
C7001	23S40657F10	Electrolytic, 10 uF/16V
C7002	23S40657F10	Electrolytic, 10 uF/16V
C7003	23T42477F06	Electrolytic (B.P), 10 uF/16V
C7004	23T42477F06	Electrolytic (B.P), 10 uF/16V
C7005	23S40657F10	Electrolytic, 10 uF/16V
C7006	23S40657F10	Electrolytic, 10 uF/16V
C7007	23S40657F14	Electrolytic, 100 uF/16V
C7008	23S40657F14	Electrolytic, 100 uF/16V
C7009	23S41192U14	Electrolytic (B.P), 3.3 uF/50V
C7010	23S41192U14	Electrolytic (B.P), 3.3 uF/50V
C7011	08S44505P61	Ceramic, 0.01 uF
C7012	08S44505P61	Ceramic, 0.01 uF
C7013	23S40657F13	Electrolytic, 47 uF/16V
C7014	23S40657F13	Electrolytic, 47 uF/16V
C7201	08T52448F27	Polystyrol, 3900 pF
C7202	08T52448F27	Polystyrol, 3900 pF
C7203	23S41059P03	Tantalum, 0.22 uF/35V
C7204	08T57851F11	T.F., 0.068 uF
C7205	23S40657F13	Electrolytic, 47 uF/16V
C7206	23S40657F13	Electrolytic, 47 uF/16V
C7207	23T42477F16	Electrolytic (B.P), 1 uF/50V
C7208	23T42477F06	Electrolytic (B.P), 10 uF/16V
C7801	08S44505P61	Ceramic, 0.01 uF

Symbol No.	Part No.	Description
C7802	08S44505P49	Ceramic, 1000 pF
C7803	08T57851F19	T.F., 0.33 uF
C7804	23S40657F13	Electrolytic, 47 uF/16V
C7805	23S40657F13	Electrolytic, 47 uF/16V
C7806	08S44505P61	Ceramic, 0.01 uF
C7807	23S40657F16	Electrolytic, 4.7 uF/25V
C7808	08S44505P61	Ceramic, 0.01 uF
FL Meter P.C. Board		
IC's		
IC7501	51T62570F01	AN6870
IC7502	51T62571F01	LB1290
IC7503	51T62571F01	LB1290
IC7504	51T62571F01	LB1290
IC7505	51T62571F01	LB1290
Transistors		
Q7501	48S40832F03	2SC1318NC-R
Q7503	48S40832F03	2SC1318NC-R
Diodes		
D7501	48T51582F01	MA-150
or	48T51881F01	DS442-BT
ZD7501	48T52739F49	Zener, HZ7C-1
ZD7503	48T52739F79	Zener, HZ16-C
Inductors		
L7501	24S41448F91	Inductor, Radial 1mH
Resistor		
VR7501	18T61417F10	Variable, 10K ohm

Symbol No.	Part No.	Description
Capacitors		
C7501	23S40657F21	Electrolytic, 100 uF/25V
C7502	23S40657F18	Electrolytic, 22 uF/25V
C7505	23S40657F21	Electrolytic, 100 uF/25V
C7506	23S40657F17	Electrolytic, 10 uF/25V
C7507	23S40657F10	Electrolytic, 10 uF/16V
C7508	08T57851F09	T.F., 0.047 uF
Counter P.C. Board		
IC's		
IC7701	51T62572F01	LB1293
IC7702	51T62572F01	LB1293
FL Tube		
FL7701	65T62567F01	FL, Counter
Keyboard Switch P.C. Board		
Diodes		
LD6301	48T52607F01	LED (RED) TLS 163 (REC/MUTE)
LD6302	48T52608F01	LED (YEL) TLUY 163 (PAUSE)
LD6303	48T52606F01	LED (GRN) TLUG163 (FF/CUE)
LD6304	48T52606F01	LED (GRN) TLUG 163 (PLAY)
LD6305	48T52606F01	LED (GRN) TLUG 163 (REW/REVIEW)
LD6306	48T52607F01	LED (RED) TLS 163 (REC)

Symbol No.	Part No.	Description
Switches		
S6301	40T51411F01	Switch, Tact (BLK)-5 (REC/MUTE)
S6302	40T51411F01	Switch, Tact (BLK)-5 (PAUSE)
S6303	40T51411F01	Switch, Tact (BLK)-5 (FF/CUE)
S6304	40T51411F01	Switch, Tact (BLK)-5 (PLAY)
S6305	40T51411F01	Switch, Tact (BLK)-5 (REW/REVIEW)
S6306	40T51411F01	Switch, Tact (BLK)-5 (REC)
S6307	40T51411F01	Switch, Tact (BLK)-5 (STOP)
Volume/Switch P.C. Board		
Switches		
S3901	40T62574F01	Push, SEA (DOLBY ON/OFF)
S3902	40T62574F01	Push, SEA (MPX FILTER)
S3903	40T62574F01	Push, SEA (B/C)
S6601	40T62574F01	Push, SEA (METAL 50/70)
Resistors		
VR2301	18T60079F01	Variable, SA0B 1 ohm (REC)
VR2302	18T60079F01	Variable, SA0B 1 ohm (LEVEL)
Capacitors		
C3901	23S40657F10	Electrolytic, 10 uF/16V
C3902	23S40657F10	Electrolytic, 10 uF/16V
C3903	23S40657F10	Electrolytic, 10 uF/16V

Symbol No.	Part No.	Description
Sub Keyboard P.C. Board		
Switches		
S6401	40T51411F01	Switch, Tact (BLK)-5 (LENGTH)
S6402	40T51411F01	Switch, Tact (BLK)-5 (RESET)
S6403	40T51411F01	Switch, Tact (BLK)-5 (MEMORY)
S6404	40T51411F01	Switch, Tact (BLK)-5 (CALL)
S6405	40T51411F01	Switch, Tact (BLK)-5 (AUTO PLAY)
S6406	40T51411F01	Switch, Tact (BLK)-5 (AUTO REW)
Level Volume P.C. Board		
Resistors		
VR5851	18T62575F01	Volume, Rotary K09110 10K ohm (REC)
VR5852	18T62575F01	Volume, Rotary K09110 10K ohm (CAL)
Miscellaneous		
C1	08S40154T63	Capacitor, Ceramic 0.022 μ F
C2	08S40154T63	Capacitor, Ceramic 0.022 μ F
C1501	08T57437F09	Capacitor, Ceramic 0.01 μ F
C1901	23T64327F04	Capacitor, Electrolytic 0.047 μ F/16V
FL7501	65T62568F01	FL Meter
HD2001	88T58769F01	Head, R/P C.W.Z.
HD5001	88T52095F01	Head, Erase
J4551	09T65373F01	Jack, Head Phone
J4552	09T52570F02	Jack, Plate Phone
J6901	09T53104F01	Remote Control Connector (8P)

Symbol No.	Part No.	Description
LD6201	48T60878F01	LED, SLF Cassette Door (GRN)
LD6501	48T52606F01	LED, TLUG163 Auto REW (GRN)
LD6502	48T52606F01	LED, TLUG163 Auto Play (GRN)
LD6503	48T52607F01	LED, TLS163 Memory (RED)
M1	59T61067F01	Assembly, D/D Motor
M2	59T60190F01	Assembly, Reel Motor
M3	01V63400F09	Assembly, Drive Motor
P1501	● 09T60095F01	Jack, AC Plug
S1-1	40T60329F01	Switch, Leaf
S1-2	40T60329F01	Switch, Leaf
S1-3	40T60329F01	Switch, Leaf
S1-4	40T60329F01	Switch, Leaf
S2	40T60206F01	Switch, Rotary Encoder
S1501	40T45561F02	Switch, Power (SDL1P)
S6701	40T51411F01	Switch, Tact (BLK) (Monitor)
S6801	40T55489F01	Switch, Slide SSA (Timer)
S7201	40T62573F02	Switch, Rotary SBM (Test OSC)
T1001	● 25T62566F01	Trans, Power
T1001	■ 25T66053F01	Trans, Power
VR1	18V44064J10	Resistor, Variable 22K ohm 1/2W
VR4801	18T60151F01	Volume, Rotary 5K ohm-A (Output Level)
VR5051	18T62575F01	Volume, Rotary K09110 10K ohm (Bias)
VR5052	18T62575F01	Volume, Rotary K09110 10K ohm (Bias)

Note: ● : AK model only, ■ : JA model only, Others: Common

Destination's Parts List

Symbol No.	Description	POWER SOURCE	
		AK 230V	JA 100V
		Europe	Japan
F1001	Fuse	65T42077U13	Not Used
F1002	Fuse	65T42077U13	Not Used
F1003	Fuse	65T42077U17	Not Used
F1004	Fuse	65T42077U17	Not Used
F1006	Fuse	65T42077U16	Not Used
P1501	Plug, AC Cord (J)	Not Used	28T66771F01
P1501	Jack, AC Plug	09T60095F01	Not Used
T1001	Trans, Power	25T62566F01	25T66053F01
93	Assembly, Mother P.C. Board	※	※
94	Cover, Rear	15D62067F03	15D62067F02
95	Screw, Bind (M3 x 6)	03S43997P76	Not Used
97	Chassis, Bottom	※	※
107	Stopper Cord	Not Used	43B41625J01
401	Carton, Packing	56S60482F98	56S60482F87
405	Assembly, Pamphlet	01V71300F80	01V69500F78
405-2	Plut, Audio Cable	28T67347F01	28T55189F01
405-3	Manual, Owner's	68P70001F21	68P67499F64
407	Sack, Polyethylene	Not Used	56B40230G08

Note: ※ The parts whose parts numbers are not entered will not be supplied.

Packing Method View

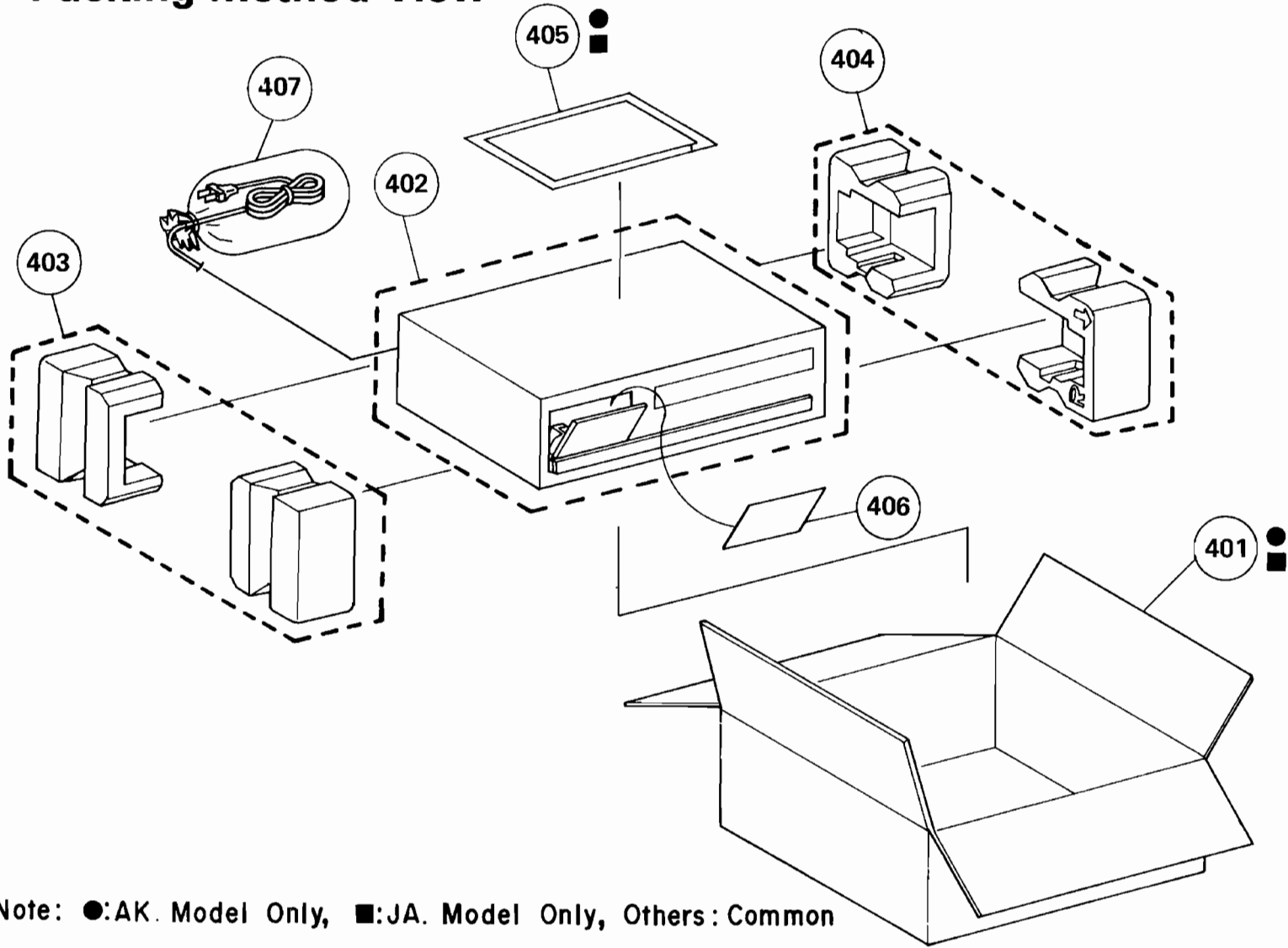

Note: ●:AK. Model Only, ■:JA. Model Only, Others: Common

Packing Assembly Parts List

Symbol No.	Part No.	Description
401	● 56S60482F98	Carton, Packing
401	■ 56S60482F87	Carton, Packing
402	56B40442T07	Packing, Front Frame
403	56D62091F01	Tray, Packing
404	56D62091F02	Tray, Packing
405	● 01V71300F80	Assembly, Pamphlet
405	■ 01V69500F78	Assembly, Pamphlet
405-1	※	Sack, Polyethylene
405-2	● 28T67347F01	Plug, Audio Cable
405-2	■ 28T55189F01	Plug, Audio Cable
405-3	● 68P70001F21	Manual, Owner's
405-3	■ 68P67499F64	Manual, Owner's
406	56B40442T11	Packing, Front Frame
407	■ 56B40230G08	Sack, Polyethylene

Symbol No.	Part No.	Description
Labels		
	54B42124G08	Serial No. (Rear Cover, Carton Packing)
	■ 54B60551F01	Seral No. (Rear Cover)
	● 54B44257U09	Label Volt (Carton Packing)
	● 54B57610F11	Serial No. (Rear Cover)

Note: ● : AK model only, ■ : JA model only, Others: Common

Cabinet Assembly Parts List

Symbol No.	Index	Part No.	Description
1		03S40036U01	Screw, W/Washer (M4 x 8)
2	1-A	15C62069F01	Cover, Top
3	2-A	01A63066F01	Assembly, Door Frame
4	2-A	61A62090F01	Crystal, Door
5	3-A	46A62089F01	Stud, Special
6	3-A	※	Assembly, Counter/Switch & Volume P.C. Board
7	3-A	61B62080F01	Crystal, Meter
8	4-A	03S40012G78	Screw, Tapping (M2 x 6)
9	4-A	01V63700F79	Assembly, Sub Keyboard P.C. Board
10		03A44642J03	Screw, Bind (M3 x 5)
11	4-A	07C62553F01	Frame, Knob
12	4-A	64B62079F02	Plate, Volume
13		03S44205G16	Screw, Countersink (M3 x 6)
14		03S40012G98	Screw, Tapping (M3 x 8)
15		29A41814G01	Lug, Wrap Around
16	4-B	26B66226F01	Shield P.C. Board
17	4-B	36B58936F05	Knob, Record (Length)
18	4-B	36B58936F06	Knob, Record (Reset)
19	4-B	36B58936F04	Knob, Record (Memory)
20	4-B	36B58936F07	Knob, Record (Call)
21	4-B	36A58935F02	Knob, Slide Volume
26		03S40011G65	Screw, Round (M3 x 4)
27	4-B	36B58936F09	Knob, Record (A. Rew)
28	4-B	26B58936F08	Knob, Record (A. Play)
29	5-B	03A44642J02	Screw, Bind (M3 x 8)
30	5-B	01V63700F81	Assembly, Keyboard Switch P.C. Board
31	6-B	01V63700F61	Assembly, Front Panel
32	2-C	02S40000G35	Nut, Hex (M3)
33	2-C	04S40071G11	Washer, Spring Lock (M3.1)
34	3-C	36A60235F02	Knob, Power
35	3-B	03D40014G06	Screw, W/Washer (M2.6 x 5)
36	3-B	36A60109F02	Knob, Rotary
37	3-B	36A55392F01	Knob, Slide Switch
38	3-B	01V63700F77	Assembly, Counter P.C. Board
39	3-C	36A55908F02	Knob, Balance
40	5-C	36A50729F01	Knob, Cassette Control
41		03S44205G38	Screw, Bind (M3 x 6)
43		03S40012G28	Screw, Tapping (M3 x 8)
44	3-C	14S53018F81	Insulator, Cover
45	3-C	※	LED P.C. Board

Symbol No.	Index	Part No.	Description
46	4-C	01V63700F76	Assembly, Volume/Switch P.C. Board
47	3-C	26A65327F01	Volume Shield
48	4-C	75S62361F37	Cushion, Rubber
49	5-C	03S40012G63	Screw, Tapping (M2 x 8)
50		36B62097F01	Knob, Function
52	5-C	01B62078F01	Assembly, Function Switch P.C. Board
53	1-D	15B61798F01	Cover, Cassette
54	1-D	04S40075G10	Washer, Polyslider (M2.6)
55		03S44205G41	Screw, Pan (M2.6 x 4)
56	3-D	※	Timer Switch P.C. Board
58	4-D	01T62663F34	Assembly, Connector
59		75A60070F01	Pad, Rubber
60	3-D	※	Test Tone Switch P.C. Board
61	4-D	※	Cover, Bottom
62	5-D	43A61729F02	Spacer, Rubber
63	5-D	※	Monitor Switch P.C. Board
64	3-D	45B57186F01	Lever, Knob
65	3-D	※	Output Volume P.C. Board
66	1-D	26A56994F01	Head Shield
67	1-D	※	Bracket, Deck Support
68	2-D	01U60000F64	Cassette Deck (FD87P020)
69	2-D	※	Assembly, FL Meter P.C. Board
71	3-D	※	Assembly, Level Volume
72	3-D	※	Head Phone P.C. Board
73	3-D	※	Bias Volume (L) P.C. Board
74	3-D	※	Bias Volume (R) P.C. Board
75	4-D	※	Chassis, Front
76	3-E	05B41635J03	Push, Rivet
77	3-E	※	Shield, FL Meter P.C. Board
78	4-E	07C62083F01	Frame, Meter Holder
79		03C42723U01	Screw, Cup (M3 x 6)
80	4-E	※	Shield, Pre-Amp
81	1-E	※	Heat Sink
82	2-E	03D40014G09	Screw, W/Washer (M3 x 5)
83	2-F	03S52360F14	Screw, Countersink (M4 x 8)
84	2-F	43T53136F01	Bush, Cap
85	3-F	03S44205G50	Screw, Countersink (M3 x 6)

Note: ※ The parts whose parts numbers are not entered will not be supplied.

Symbol No.	Index	Part No.	Description
86		09T45548F01	Order, Fuse
87		※	Heat Sink
88	1-F	※	Assembly, Control P.C. Board
89	2-F	14S53018F80	Insulator, Cover
90	2-F	※	Bracket, Trans
91	1-F	42B62861F01	Clip, Hinge
92		03D40014G10	Screw, W/Washer (M3 x 8)
93	● 5-F	※	Assembly, Mother P.C. Board
93	■ 5-F	※	Assembly, Mother P.C. Board
94	● 1-G	15D62067F03	Cover, Rear
94	■ 1-G	15D62067F02	Cover, Rear
95	● 1-G	03S43997P76	Screw, Bind (M3 x 6)
96	2-G	※	Remote Din P.C. Board
97	● 3-G	※	Chassis, Bottom
97	■ 3-G	※	Chassis, Bottom
98	1-H	54A61184F02	Label, Cover
99	1-H	03S40011G91	Screw, Bind (M2.6 x 5)
100	2-H	※	Phono Plate P.C. Board
101	4-H	※	Bracket, P.C. Board
102	5-H	※	Chassis, Side
103		03S40012G41	Screw, Tapping (M3 x 8)
104	4-G	29A737272	Lug, Wrap Around
105	4-H	※	Assembly, Tone OSC P.C. Board
106	4-D	41A70891F01	Spring, Earth
107	■	43B41625J01	Stopper Cord

Symbol No.	Part No.	Description

Note: ● : AK model only, ■ : JA model only, Others: Common

Note: ※ The parts whose parts numbers are not entered will not be supplied.

Exploded View (Cabinet)

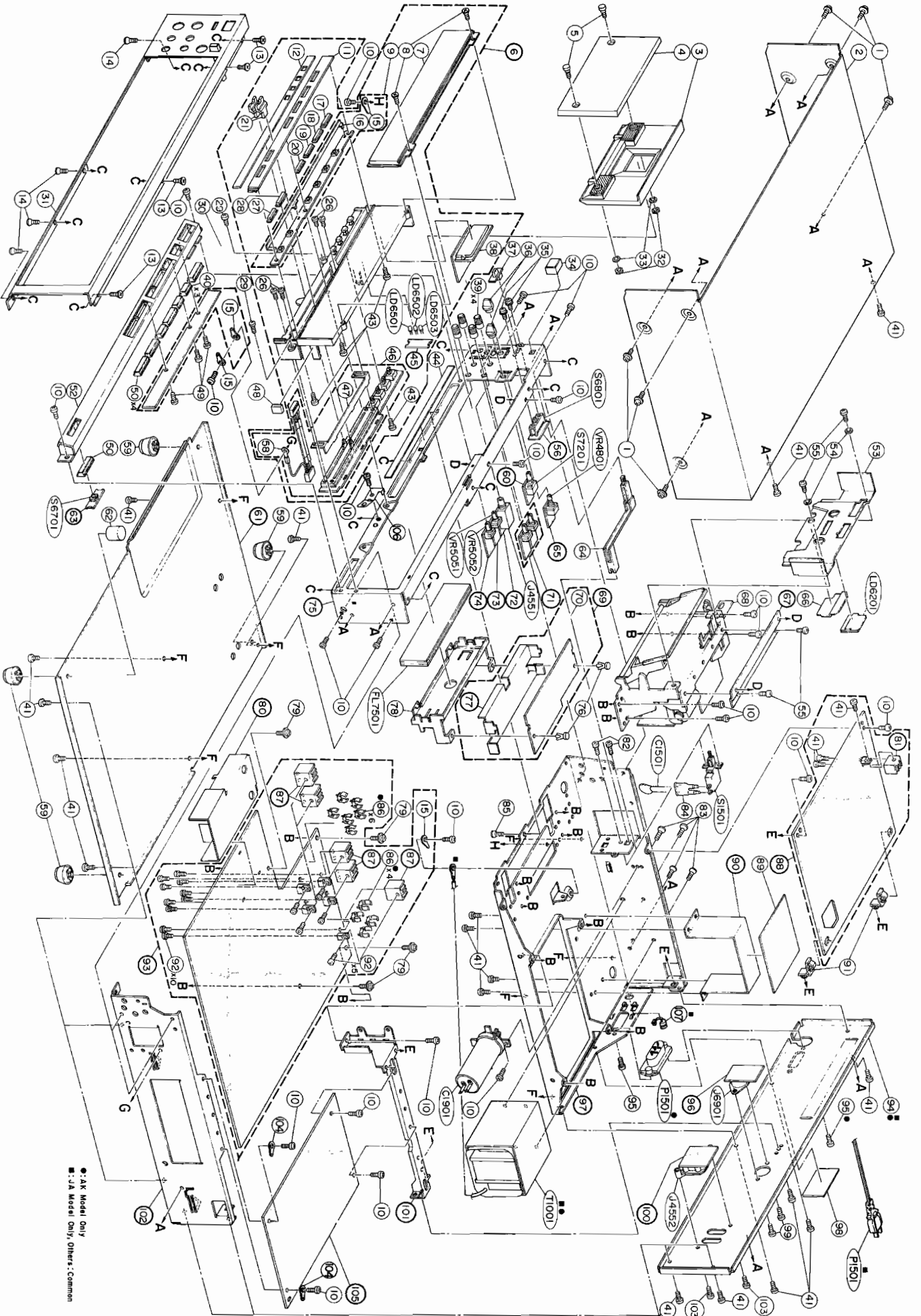

●: AK Model Only
 ■: JA Model Only; Others: Common

Exploded View (Cassette Deck)

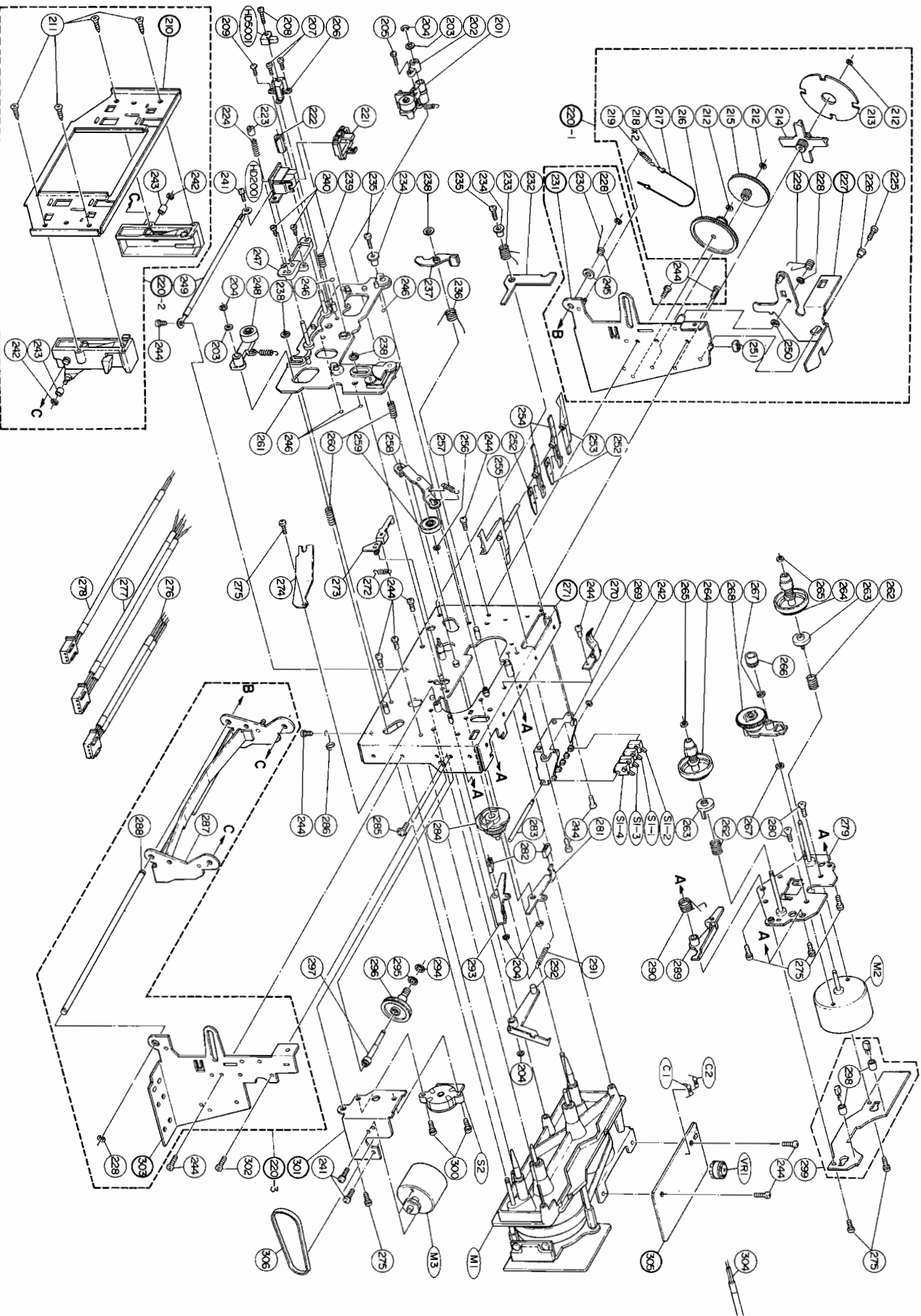

Cassette Deck Assembly Parts List

Symbol No.	Index	Part No.	Description
201	3-A	01A61172F01	Assembly, S-Pinch
202	3-A	07A60270F01	Bracket, S-Pinch Adjust
203		04S40075G12	Washer, Polyslider (M5.4)
204		04C42091G05	Ring "E" (M2)
205	4-A	03A43655U02	Screw, Torque Limit (M2 x 7)
206	4-A	15A60255F01	Housing, Erase Head
207	4-A	03S40011G30	Screw, Pan (M2 x 6)
208	4-A	03D40014G15	Screw, W/Washer (M2 x 8)
209	4-A	03A43146G01	Screw, Truss (M2 x 6)
210	5-A	※	Bracket, Cassette
211	5-A	03S40012G48	Screw, Tapping (M3 x 6)
212		04A41345P01	Washer, Lock (M1.2)
213	1-B	49A52922F01	Wheel, Damper
214	2-B	44A53019F01	Gear, Damper (C)
215	2-B	44A52924F01	Gear, Damper (B)
216	2-B	44A52923F01	Gear, Damper (A)
217	2-B	30S43803G05	Dial Cord (180mm)
218	2-B	05A44852G02	Eyelet
219	2-B	41A60285F01	Spring, Damper
220		※	Assembly, Bracket Door
221	4-B	01V58900F19	Assembly, Pad Lifter
222	4-B	02A60263F01	Nut, Azimuth
223	4-B	02A60838F01	Nut, Stopper
224	4-B	41A60193F03	Spring, Push
225	1-B	03S44205G34	Screw, Pan (M2.6 x 5)
226	1-B	43A60764F01	Bush, Arm Eject
227	1-B		Arm, Eject
228		04C42091G04	Ring "E" (M3)
229	1-B	41A62693F01	Spring, Lock
230	3-B	41A50740F01	Spring, "C" Lever
231	3-B	※	Assembly, Deck Bracket "L"
232	3-B	45A60797F01	Arm, Eject Stopper
233	3-B	41A60801F01	Spring, Eject Stopper
234		43A60798F01	Spacer, Screw
235		03S44205G33	Screw, Pan (M2.6 x 8)
236	3-C	41A60268F01	Spring, B.T.
237	3-C	45A60266F01	Arm, Back Tension
238		04A41345P04	Washer, Lock (M6)
239	4-B	41A60193F04	Spring, Push
240	4-B	03A43655U01	Screw, Torque Limit (M2 x 5.5)

Symbol No.	Index	Part No.	Description
241		03D40014G07	Screw, W/Washer (M2 x 4)
242		04C42091G12	Ring, "E" (M1.2)
243		43A60304F01	Sleeve Holder
244		03S44205G34	Screw, Pan (M2.6 x 5)
245	2-C	04S40070G35	Washer (M4.2)
246		43A41182P01	Ball, Steel (M2)
247	4-C	15A60273F01	Housing, R/P Head
248	4-C	01A61171F01	Assembly, T-Pinch
249	5-C	01T62672F01	Assembly, Earth Wire
250	1-C	04S40075G17	Washer, Polyslider (M4.1)
251	2-C	75A60759F01	Lubber, Eject
252		41A60758F01	Spring, Rec
253	2-D	45A60754F01	Arm, Pack
254	3-C	45A60330F01	Arm, Rec
255	3-D	41A61188F01	Assembly, Arm Metal
256	3-D	04S40075G02	Washer, Polyslider (M1.7)
257	3-D	41B60230F02	Spring, Pull
258	4-D	01A60208F01	Assembly, Lever Play
259	4-D	49A60209F01	Roller, Play Idler
260	4-D	41A60193F05	Spring, Push
261	4-D	01A60897F01	Assembly, Head Base
262		41A60193F01	Spring, Push
263		49A60192F01	Pulley, Back Tension
264		01T62785F01	Assembly, Reel
265		04S40075G03	Washer, Polyslider (M1.7)
266	2-E	49A60191F01	Pulley, Reel Sensor
267		04S40075G05	Washer, Polyslider (M4)
268	2-D	01T60835F01	Assembly, FF/REW Clutch
269	2-D	07B60755F01	Frame, Switch
270	2-D	41A60222F01	Spring, Cassette
271	3-D	※	Assembly, Chassis Base
272	4-D	41B60230F03	Spring, Pull
273	4-D	45A60217F01	Arm, Pause
274	4-D	41A60269F01	Spring, Ball
275		03D40014G12	Screw, W/Washer (M2.6 x 4)
276	5-D	01T60761F01	Assembly, Head Cable
277	5-D	01T60761F02	Assembly, Head Cable
278	5-D	01T60763F01	Assembly, Erase Head Wire
279	1-F	01A60187F01	Assembly, Motor Reel Bracket
280	2-F	03S40011G95	Screw, Countersink (M2.6 x 4)

Note: ※ The parts whose parts numbers are not entered will not be supplied.

Symbol No.	Index	Part No.	Description
281	2-F	45A60214F01	Arm, Brake "L"
282	3-F	75A60213F01	Luber, Brake
283	3-F	47A60756F01	Shaft, Switch
284	3-F	44B60220F01	Gear, Drive Cam
285	4-F	03C40121T10	Screw, W/Double Washer (M2.6 x 4)
286	4-F	41A62309F01	Spring, Wire Through
287	5-F	45B60707F02	Bracket, Deck "R"
288	5-F	47A50720F02	Shaft, Deck
289	2-F	45A60216F01	Arm, FF/REW Release
290	2-F	41A60231F01	Spring, F/R Release
291	2-F	41B60230F01	Spring, Pull
292	3-F	45A60215F01	Lever, Brake
293	3-F	45A60212F01	Arm, Brake "R"
294	3-F	04A41345P06	Washer, Lock (M2.1)
295	4-F	04S40075G08	Washer, Polyslider (M2.6)
296	4-F	44A60219F01	Worm Drive
297	4-F	47A60218F01	Shaft, Worm Gear
298	1-G	43A60239F01	Spacer
299	1-G	01V61400F17	Assembly, Sensor P.C. Board
300	3-G	03D40014G31	Screw, W/Washer (M2.6 x 10)
301	4-G	※	Bracket, Drive
302	4-G	03S40011G58	Screw, Pan (M2.6 x 3)
303	5-G	※	Bracket, Deck "R"
304	2-H	30A61681F01	C.W. Shield
305	2-H	※	Assembly, Wire P.C. Board
306	4-H	42A60221F01	Belt, Drive

Symbol No.	Part No.	Description

Note: ※ The parts whose parts numbers are not entered will not be supplied.

Semi-Conductor Lead Identifications

NJL5141: IC1, 2

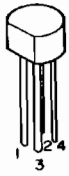

1. Cathode
2. Anode
3. Collector
4. Emitter

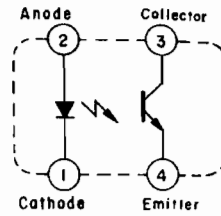

μ PC4556C: IC2001, 2501, 5501, 7801
 μ PC4558C: IC4501, 6009, 7001, 7002, 7003, 7201

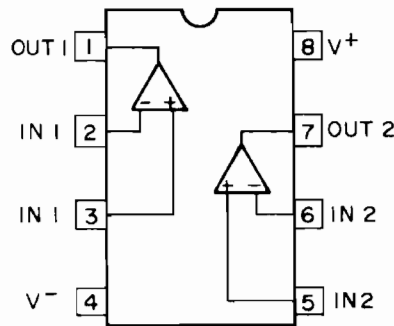
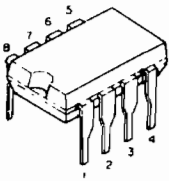

CX20027: IC3001, 3502
CX20028: IC3002, 3501

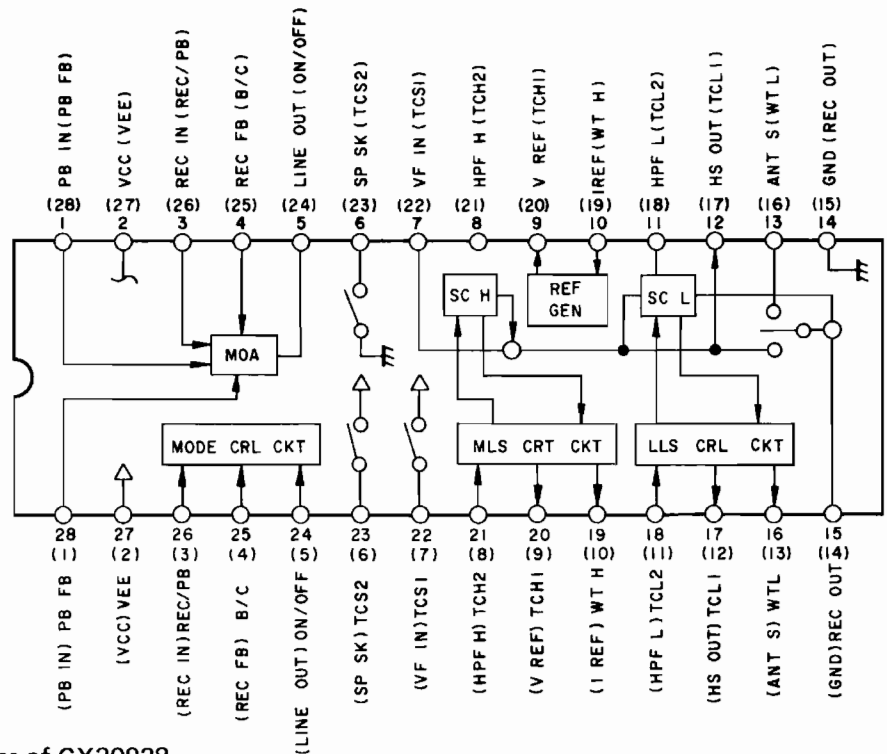
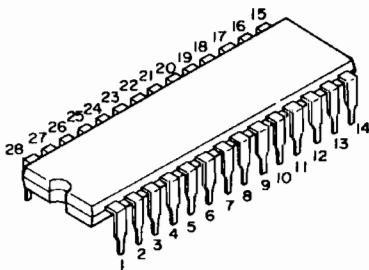

* Words put in parentheses are pin names of CX20028.

61508F01: IC6001

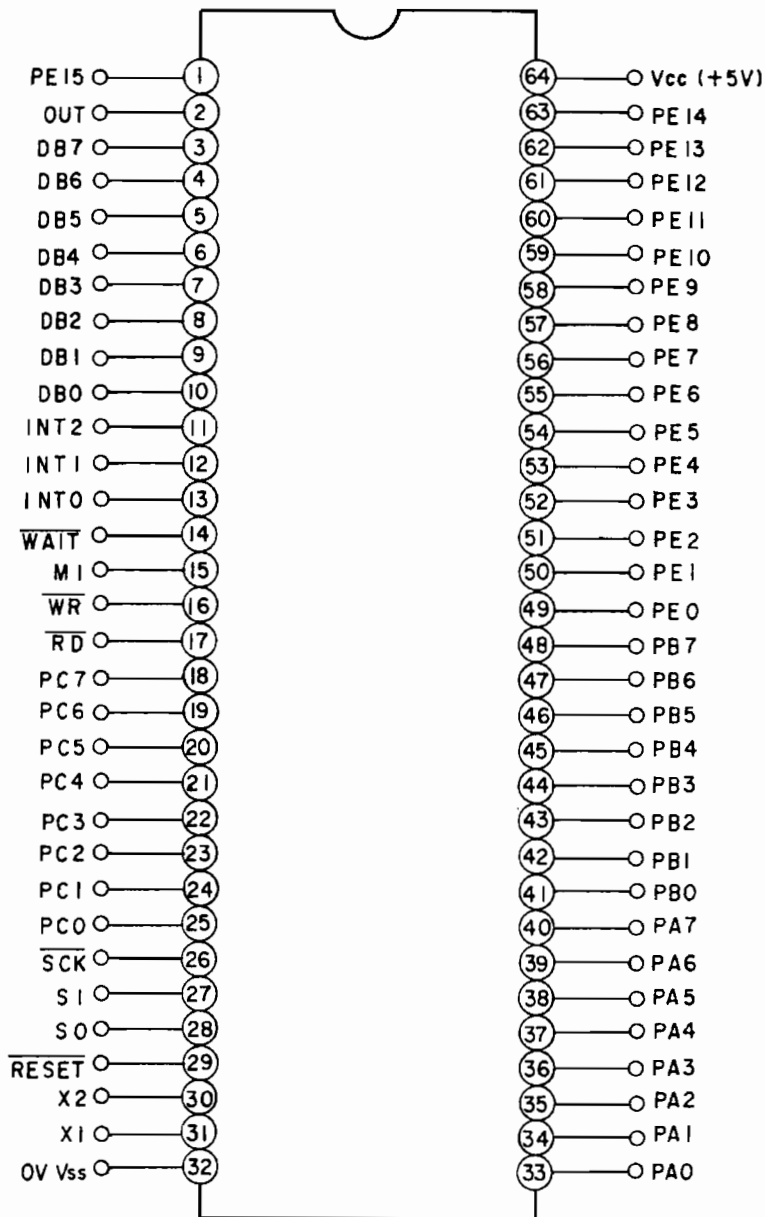
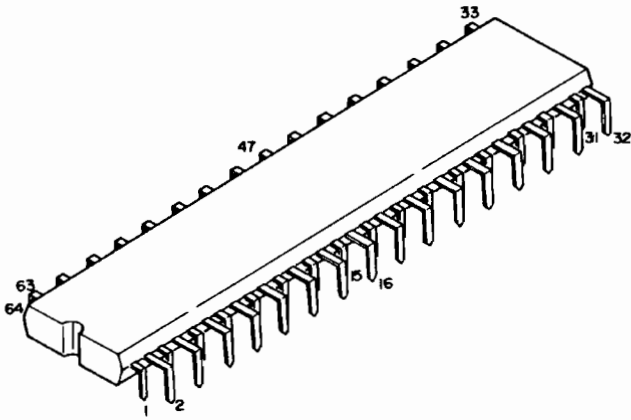

μPD2316EC: IC6002

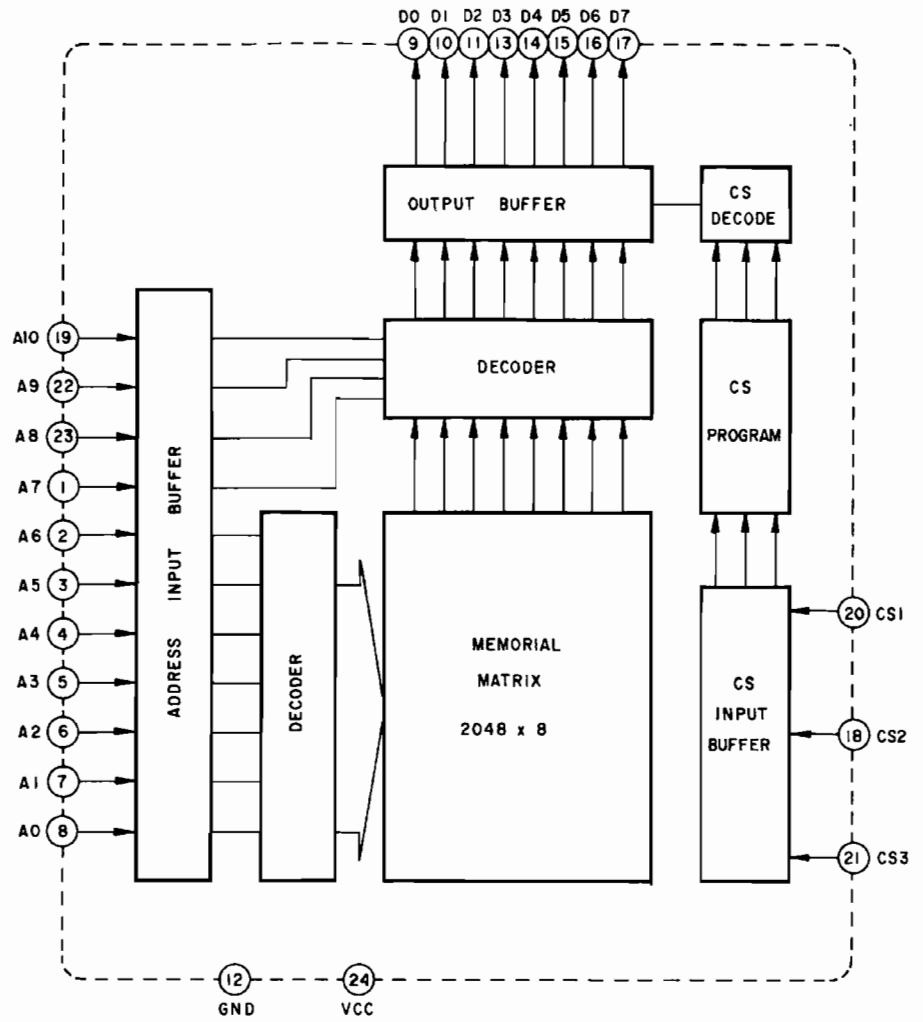
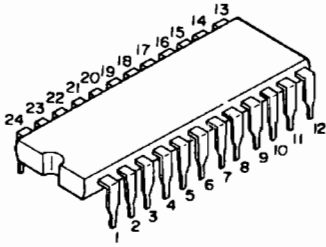

μPD4503BC: IC6003, 6004

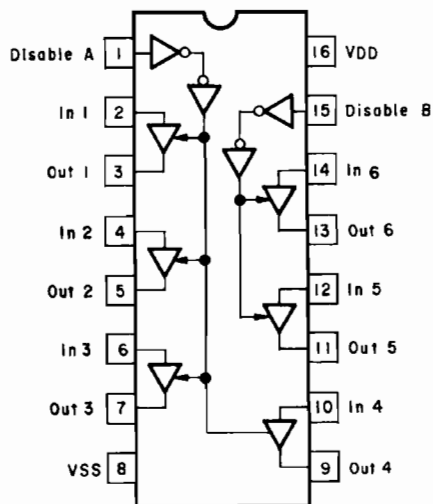
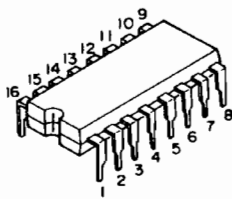

μPD82C43C: IC6005, 6006, 6007

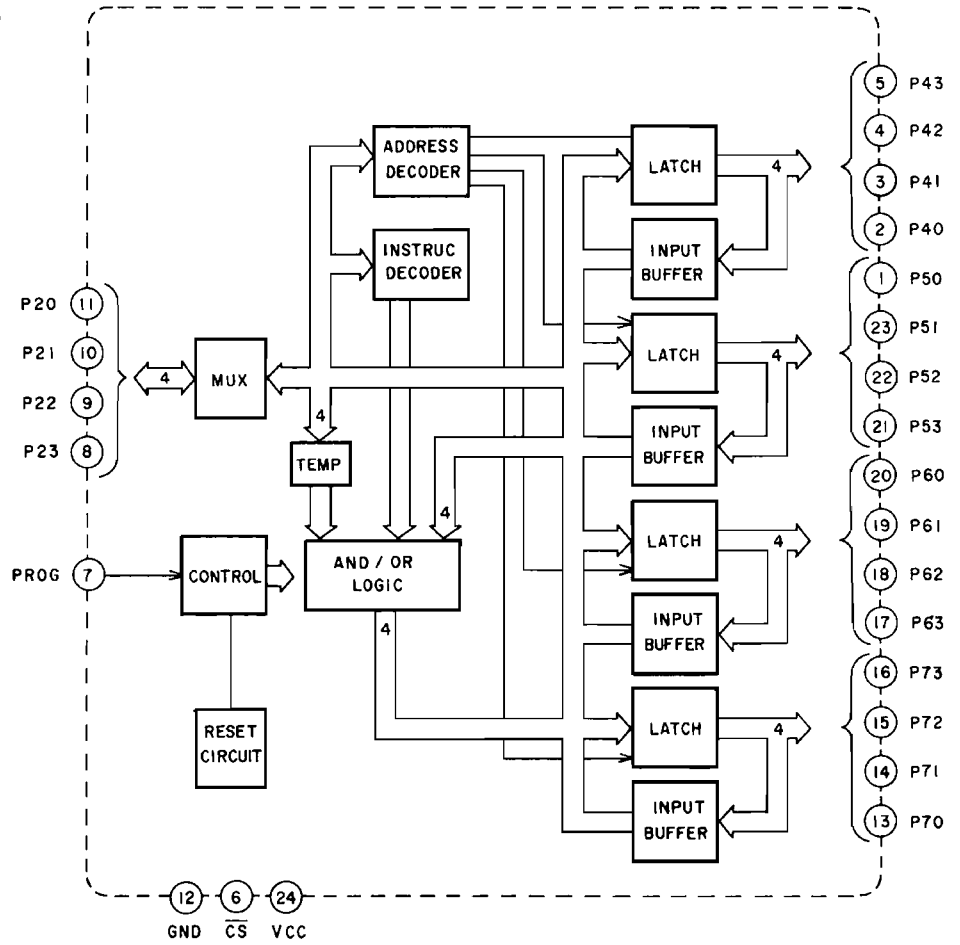
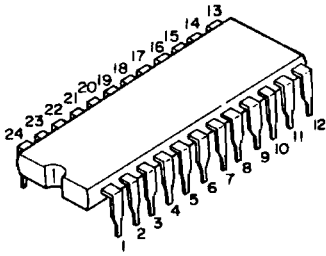

μPC4741C: IC6008

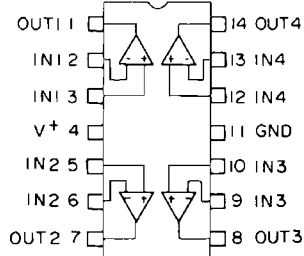
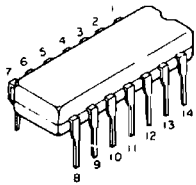

μPC393C: IC6010, 6011

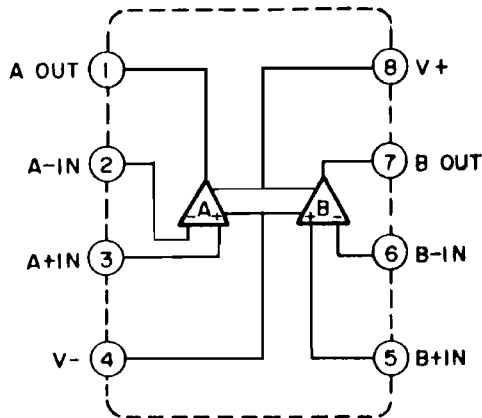
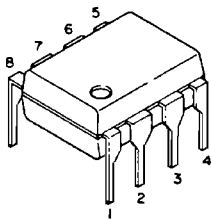

μPD4069: IC6012

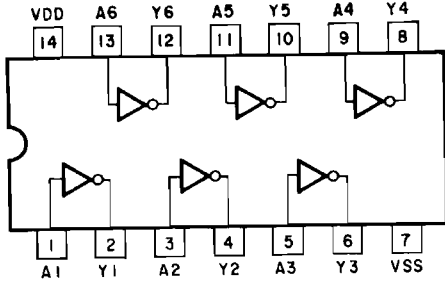
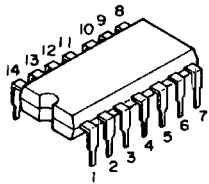

TD62504: IC6013

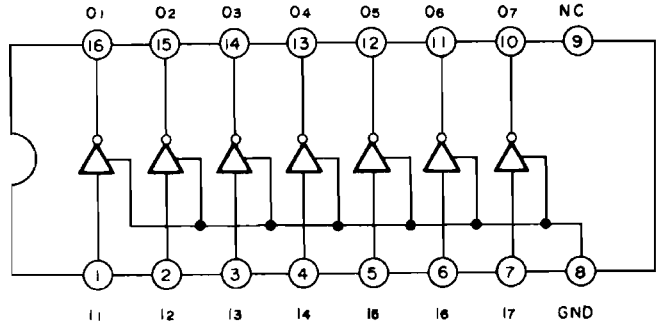
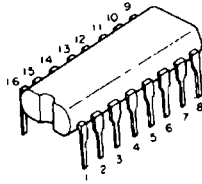

AN6870N: IC7501

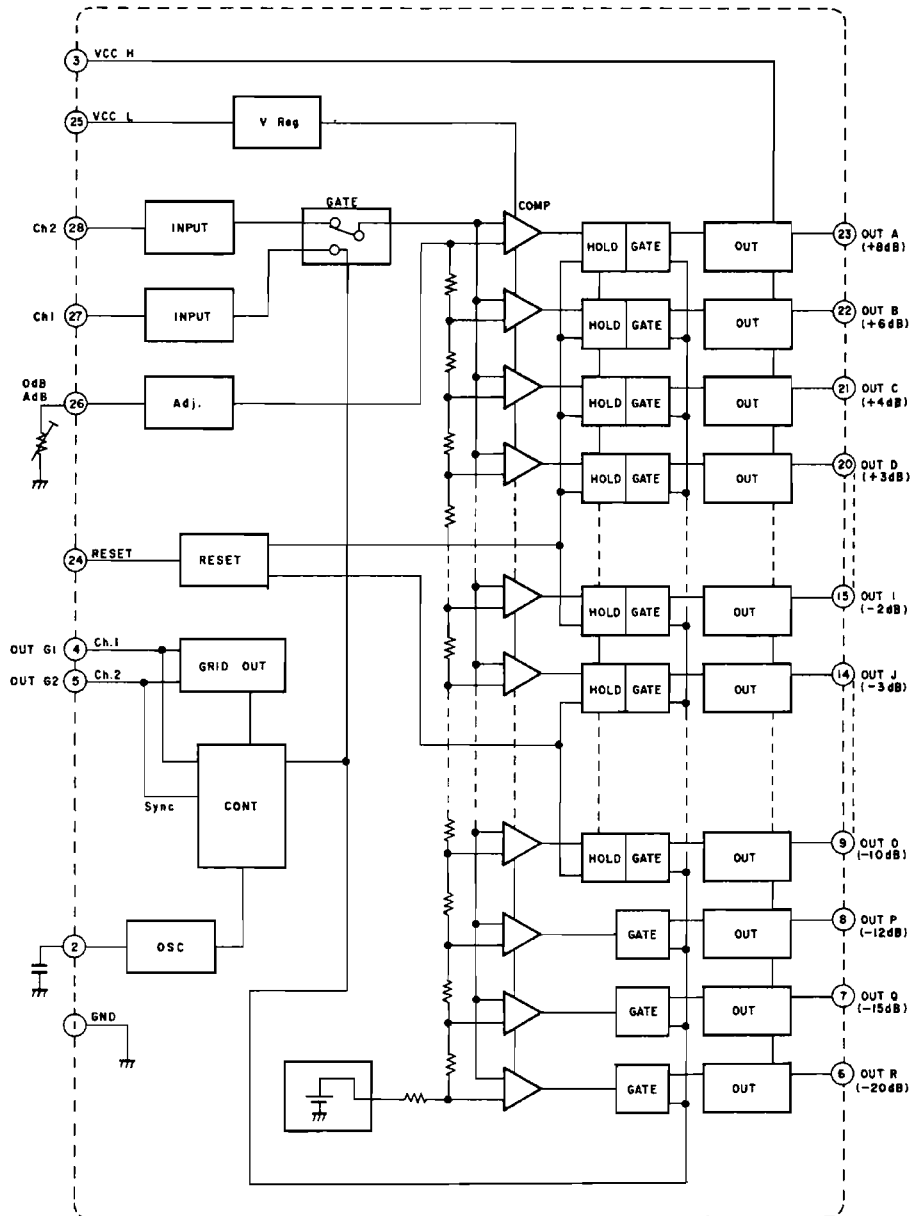
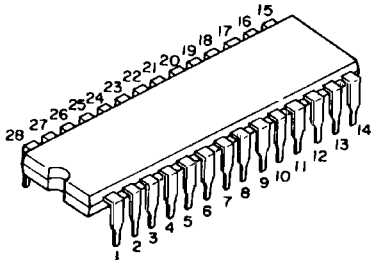

LB1290: IC7502, 7503, 7504, 7505

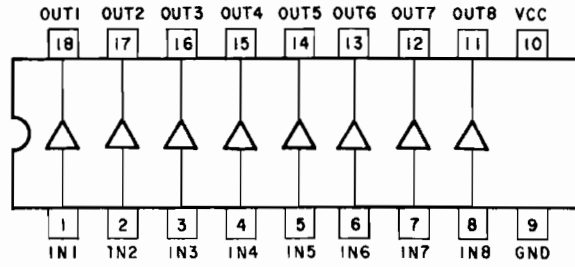
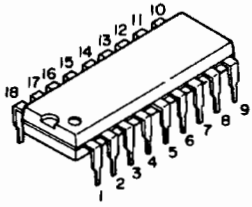

LB1293: IC7701, 7702

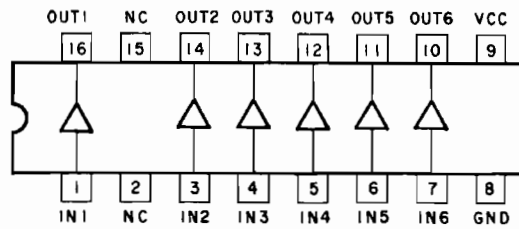
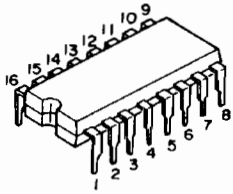

μPD4011BC: IC7802

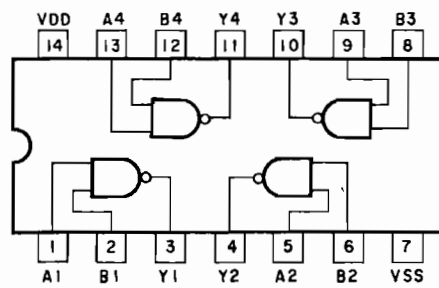
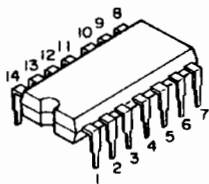

2SD601: Q1, 2

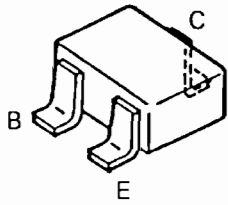

2SD1276: Q1001
2SD1266: Q1004 ~ 1007
 Q6001, 6006

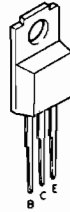

2SB560: Q1003, 2012, 5001
2SD438: Q2011, 5003, 5005
 Q5006

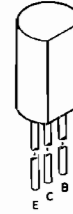

2SK240: Q2001, 2002

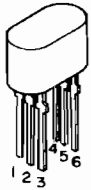

1: DRAIN 1 4: DRAIN 2
 2: GATE 1 5: GATE 2
 3: SOURCE 1 6: SOURCE 2

2SK270: Q2001, 2002

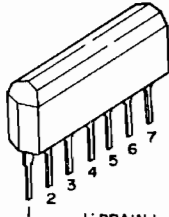

1: DRAIN 1 5: SOURCE 2
 2: GATE 1 6: GATE 2
 3: SOURCE 1 7: DRAIN 1
 4: SUBSTART

2SK163 } : Q2003 ~ 2006
2SK117 } : Q4005 ~ 4008
 Q5801 ~ 5808
 Q7201, 7202



2SK30A: Q2003 ~ 2006
 Q4005 ~ 4008
 Q5801 ~ 5808
 Q7203



2SA1015 } : Q2801
2SA733 }

2SC1815: Q2802, 3001 ~ 3004, 5002, 5007 ~ 5010
 Q5101 ~ 5106, 6024, 6025, 7801 ~ 7804

2SC1775: Q2803, 2804

2SD1302: Q2805, 2806, 4001 ~ 4004, 4009, 4010, 5501,
 Q5502, 6028

2SC1213: Q4501, 4502

2SA673: Q4503, 4504

2SB977: Q6002, 6003, 6007, 6008, 6011 ~ 6014

2SD893: Q6004, 6005, 6009, 6010

2SC2878: Q7001 ~ 7006, 7204, 7205

2SC1318: Q7501, 7503

DTC114: Q6015 ~ 6023, 6026,
 Q6027

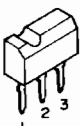

1: GND
 2: OUT
 3: IN

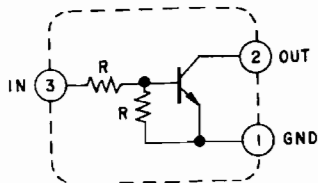

Part No.	Quantity	Description	Part No.	Quantity	Description
1C-5	1	1C200	1C201	1	1C202
Transistors (Q)					
Q1001	1	Q1002	Q1003	1	Q1004
Q1005	1	Q1006	Q1007	1	Q1008
Q1009	1	Q1010	Q1011	1	Q1012
Q1013	1	Q1014	Q1015	1	Q1016
Q1017	1	Q1018	Q1019	1	Q1020
Q1021	1	Q1022	Q1023	1	Q1024
Q1025	1	Q1026	Q1027	1	Q1028
Q1029	1	Q1030	Q1031	1	Q1032
Q1033	1	Q1034	Q1035	1	Q1036
Q1037	1	Q1038	Q1039	1	Q1040
Q1041	1	Q1042	Q1043	1	Q1044
Q1045	1	Q1046	Q1047	1	Q1048
Q1049	1	Q1050	Q1051	1	Q1052
Q1053	1	Q1054	Q1055	1	Q1056
Q1057	1	Q1058	Q1059	1	Q1060
Q1061	1	Q1062	Q1063	1	Q1064
Q1065	1	Q1066	Q1067	1	Q1068
Q1069	1	Q1070	Q1071	1	Q1072
Q1073	1	Q1074	Q1075	1	Q1076
Q1077	1	Q1078	Q1079	1	Q1080
Q1081	1	Q1082	Q1083	1	Q1084
Q1085	1	Q1086	Q1087	1	Q1088
Q1089	1	Q1090	Q1091	1	Q1092
Q1093	1	Q1094	Q1095	1	Q1096
Q1097	1	Q1098	Q1099	1	Q1100
Q1101	1	Q1102	Q1103	1	Q1104
Q1105	1	Q1106	Q1107	1	Q1108
Q1109	1	Q1110	Q1111	1	Q1112
Q1113	1	Q1114	Q1115	1	Q1116
Q1117	1	Q1118	Q1119	1	Q1120
Q1121	1	Q1122	Q1123	1	Q1124
Q1125	1	Q1126	Q1127	1	Q1128
Q1129	1	Q1130	Q1131	1	Q1132
Q1133	1	Q1134	Q1135	1	Q1136
Q1137	1	Q1138	Q1139	1	Q1140
Q1141	1	Q1142	Q1143	1	Q1144
Q1145	1	Q1146	Q1147	1	Q1148
Q1149	1	Q1150	Q1151	1	Q1152
Q1153	1	Q1154	Q1155	1	Q1156
Q1157	1	Q1158	Q1159	1	Q1160
Q1161	1	Q1162	Q1163	1	Q1164
Q1165	1	Q1166	Q1167	1	Q1168
Q1169	1	Q1170	Q1171	1	Q1172
Q1173	1	Q1174	Q1175	1	Q1176
Q1177	1	Q1178	Q1179	1	Q1180
Q1181	1	Q1182	Q1183	1	Q1184
Q1185	1	Q1186	Q1187	1	Q1188
Q1189	1	Q1190	Q1191	1	Q1192
Q1193	1	Q1194	Q1195	1	Q1196
Q1197	1	Q1198	Q1199	1	Q1200

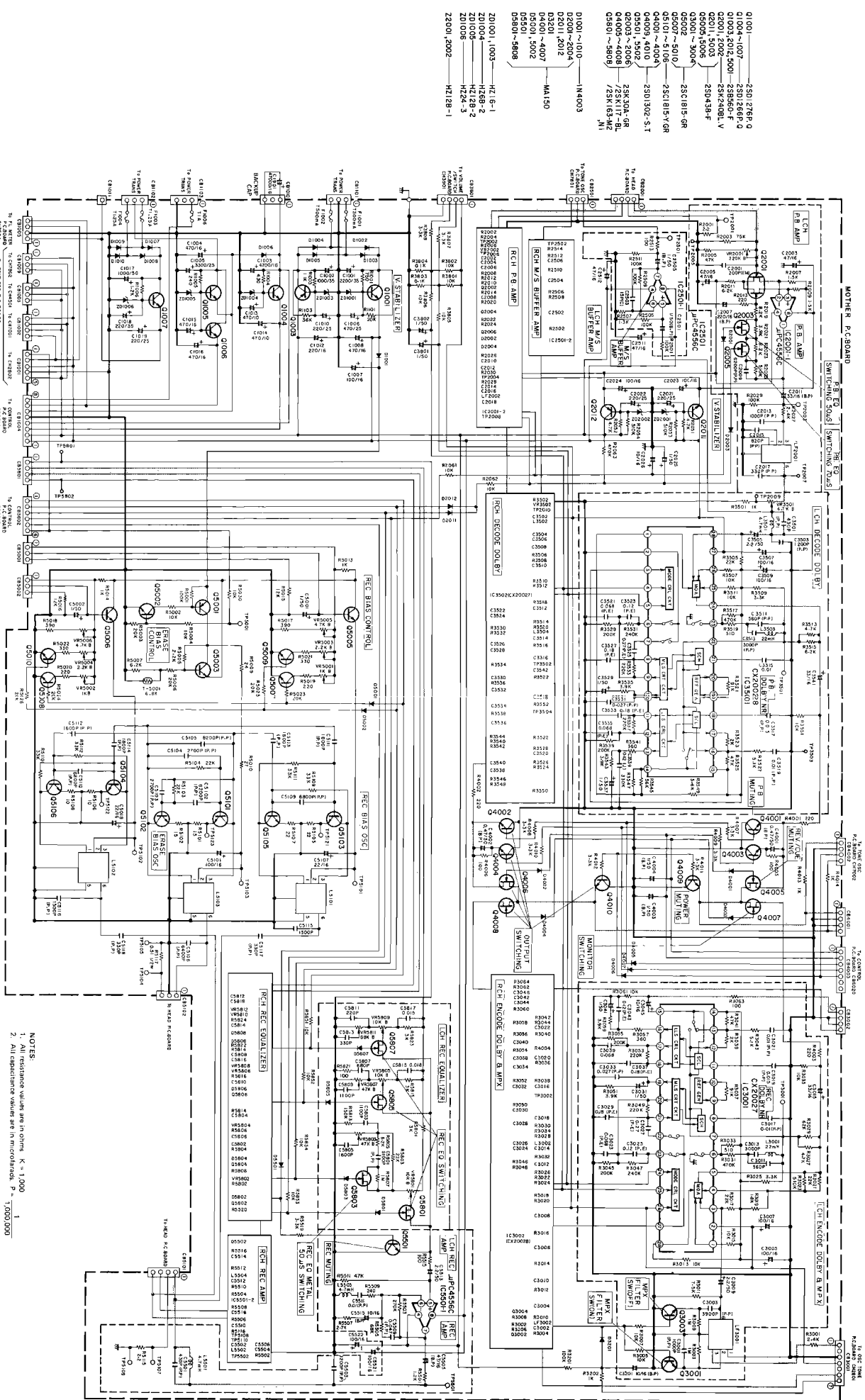

NOTES:
 1. All resistance values are in ohms. K = 1000.
 2. All capacitance values are in microfarads. P = 1,000,000.

Schematic Diagram (2/3)

IC's	1	2	3	4	5	6	7	8	9	10	11	12	13	14	15	16	17	18	19	20	21	22	23	24	25	26	27	28	29	30	31	32	33	34	35	36	37	38	39	40
Transistors (Q)																																								
Diodes (D, D1, D2, LD)																																								

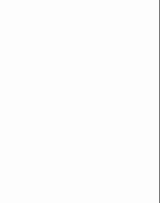
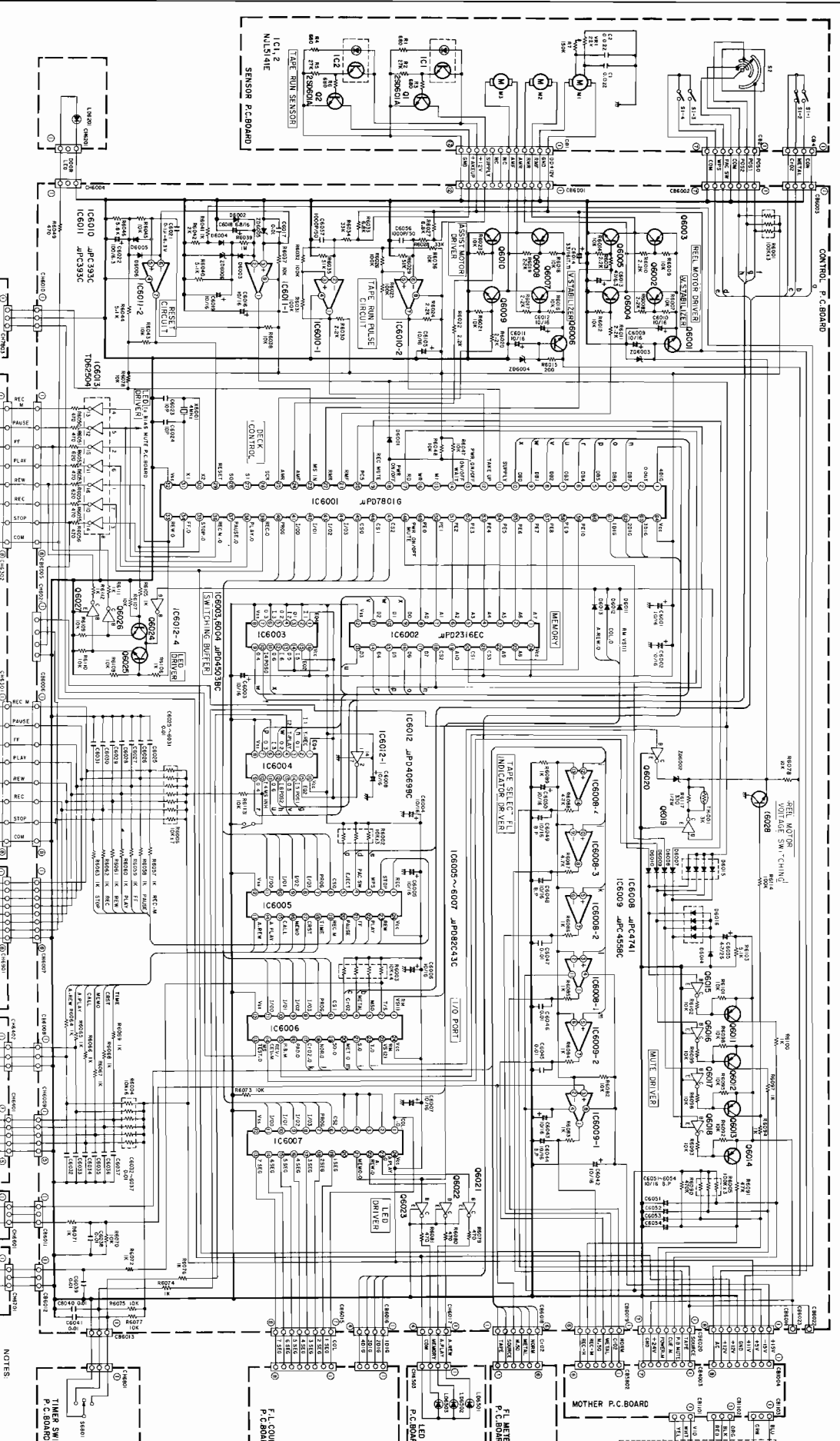

- NOTES
- All resistance values are in ohms, K = 1,000
 - All capacitance values are in microfarads, μ = 1,000,000
- | | | |
|------------|-------------|-----|
| 06001-6006 | 2SD1286 | P-C |
| 06004-6005 | | |
| 06009-6010 | 2SD1093 | |
| 06007-6008 | 2SB977 | |
| 06002-6003 | | |
| 06003-6004 | 2SC1815Y/8 | |
| 06015-6023 | DT-C-11A | |
| 06028-6027 | 2SD13023A-T | |
| 06001-6014 | MA165 | |
| 06015-6016 | DHF-401 | |
| 20602-6006 | N2C-1 | |
| 20603-6004 | 171C-1 | |
| 20605 | 172C | |

IC's		IC701	IC702	IC703	IC704	IC705	IC706	IC707	IC708	IC709	IC710	IC711	IC712	IC713	IC714	IC715	IC716	IC717	IC718	IC719	IC720	IC721	IC722	IC723	IC724	IC725	IC726	IC727	IC728	IC729	IC730	IC731	IC732	IC733	IC734	IC735	IC736	IC737	IC738	IC739	IC740	IC741	IC742	IC743	IC744	IC745	IC746	IC747	IC748	IC749	IC750
Transistor(s)		Q2801	Q2802	Q2803	Q2804	Q2805	Q2806	Q2807	Q2808	Q2809	Q2810	Q2811	Q2812	Q2813	Q2814	Q2815	Q2816	Q2817	Q2818	Q2819	Q2820	Q2821	Q2822	Q2823	Q2824	Q2825	Q2826	Q2827	Q2828	Q2829	Q2830	Q2831	Q2832	Q2833	Q2834	Q2835	Q2836	Q2837	Q2838	Q2839	Q2840	Q2841	Q2842	Q2843	Q2844	Q2845	Q2846	Q2847	Q2848	Q2849	Q2850
Diode(s) ZD1		ZD701	ZD702	ZD703	ZD704	ZD705	ZD706	ZD707	ZD708	ZD709	ZD710	ZD711	ZD712	ZD713	ZD714	ZD715	ZD716	ZD717	ZD718	ZD719	ZD720	ZD721	ZD722	ZD723	ZD724	ZD725	ZD726	ZD727	ZD728	ZD729	ZD730	ZD731	ZD732	ZD733	ZD734	ZD735	ZD736	ZD737	ZD738	ZD739	ZD740	ZD741	ZD742	ZD743	ZD744	ZD745	ZD746	ZD747	ZD748	ZD749	ZD750

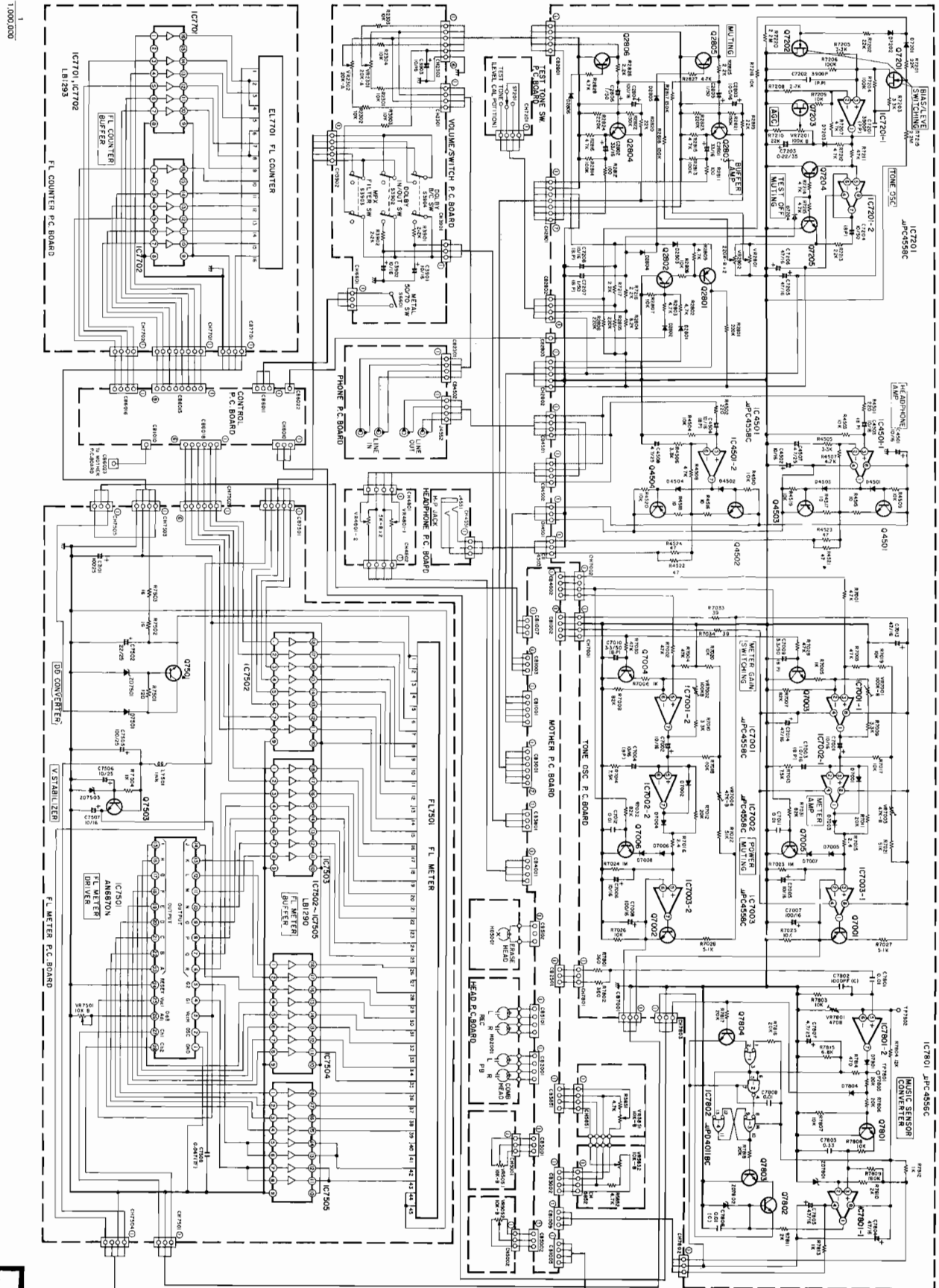

NOTES:
1. All capacitance values are in pF unless otherwise specified.
2. All capacitance values are in microfarads unless otherwise specified.



LUX CORPORATION, JAPAN

2-3, 1-Chome, Minami-Yukigaya, Ohta-ku, Tokyo 145, JAPAN
Phone: 03-726-6211 Telex: 2466953LUXMAN Facsimile: 03-728-7609

0117F01

8/85-S Printed in Japan